

**WECP**  
**(Water Engineering Contractor Packet)**

**SRP**  
**CONSTRUCTION SPECIFICATIONS**  
**AND REFERENCES**

**(PROVIDE THIS ENTIRE PACKET TO YOUR CONTRACTOR)**

**WECP**  
**(Water Engineering Contractor Packet)**

**SRP**  
**CONSTRUCTION SPECIFICATIONS**  
**AND REFERENCES**

**(PROVIDE THIS ENTIRE PACKAGE TO YOUR CONTRACTOR)**

**STANDARD SPECIFICATIONS**

SRP	02227	Salt River Project Standard Specification for Slurry Backfill Materials
WTR	02614	Salt River Project Water Group Standard Specification for for Precast Concrete Pipe
SRP	03210	Salt River Project Standard Specification for Reinforcing Steel
SRP	03300	Salt River Project Standard Specification for Concrete
SRP	03364	Salt River Project Standard Specification for Fiber Reinforced Shotcrete for Canal Bank Lining
GE	03305	Salt River Project Generation Engineering Standard Specification for Concrete Formwork and Placement

**REFERENCE DRAWINGS**

WES-FRCANLNG	Fiber-Reinforced Canal Lining Section
WES-30300-001	Pipeline Bedding/Backfill Requirements
WES-30300-003	Standard Concrete Pipe Collar
WES-SPIPECLR	Structural Concrete Pipe Collar
WES-30300-004	Rubber Gasket Joints
WES-30350-200	45° Trashrack for Pipeline Headwall

**REFERENCE LANDFILLS**

- SRP (Valley) Approved Landfills – Solid Waste Disposal Facilities
- SRP (State) Approved Landfills – Solid Waste Disposal Facilities

# **STANDARD SPECIFICATIONS**

**SALT RIVER PROJECT**  
**STANDARD SPECIFICATION**  
**FOR**  
**SLURRY BACKFILL MATERIALS**  
**(SRP 02227)**

**TABLE OF CONTENTS**

<b>SECTION</b>	<b>TITLE</b>	<b>PAGE</b>
<b>1.0</b>	<b>GENERAL</b>	<b>1</b>
1 1	Work Included	1
1 2	Reference Standards	2
1 3	Definitions	4
1 4	Submittals	4
1 5	Quality Assurance	4
1 6	Storage and Handling	4
<b>2.0</b>	<b>PRODUCT</b>	<b>5</b>
2 1	Cement	5
2 2	Fly Ash	5
2 3	Lime	5
2 4	Aggregate	5
2 5	Water	5
2 6	Admixtures	5
2 7	Measurement and Mixing of Materials	6
2 8	Mix Design for RFG Grout	6
2 9	Batching RFG Grout	6
2 10	Washed Gravel for RFG	7
<b>3.0</b>	<b>EXECUTION</b>	<b>7</b>
3 1	Delivery	7
3 2	Placement	7
3 3	Protection	8
3 4	Testing	9
3 5	Acceptance of Backfill Materials	9
	Table 1	10

Prepared By M D Voda

Reviewed By P M Kandans  
 (Revised for Metric 6/7/96)

**STANDARD SPECIFICATION  
FOR  
SLURRY BACKFILL MATERIALS  
(SRP 02227)**

**1.0 GENERAL**

**1 1 Work Included**

This specification shall cover the furnishing of all labor, equipment and materials for supplying and placing slurry-type backfills

The following is a brief description of the types of slurry backfills and their intended uses

**ASB - Aggregate Slurry Backfill -** washed gravel and sand, no cementitious materials, for use as a backfill around wood and concrete transmission line poles and trench backfill where no structural loads will be anticipated.

**LMB 1/2 SACK - Lean Mix Backfill with 1/2 Sack (21.3-kg)** portland cement per cubic yard (0.84-m<sup>3</sup>) - washed gravel and sand with cement, for use as a general trench backfill in low load areas (streets and parking areas).

**LMB 1 SACK - Lean Mix Backfill with 1 Sack (42.5-kg)** portland cement per cubic yard (0.84-m<sup>3</sup>) - washed gravel and sand with cement, for use as a general trench backfill in low load areas (streets and parking areas). Use in lieu of LMB 1/2 Sack (21.3-kg) when required by municipality

**LMB 1-1/2 SACK - Lean Mix Backfill with 1-1/2 Sacks (63.8-kg)** portland cement per cubic yard (0.84-m<sup>3</sup>) - washed gravel and sand with cement, for use as a structural backfill under foundations and as thermal fill and/or mechanical protection of duct banks

**DBA - Duct Bank Backfill w/ Aggregate -** washed gravel and sand with four sacks (170-kg) portland cement per cubic yard (0.84-m<sup>3</sup>), used as a thermal backfill/encasement for electrical ductbank with conduits spaced greater than 2 inches (51-mm) apart.

**DBS - Duct Bank Backfill w/ Sand -** washed sand with four sacks (170-kg) portland cement per cubic yard (0.84-m<sup>3</sup>), used as a thermal backfill/encasement for electrical ductbank with conduits spaced less than 2 inches (51-mm) apart and for pumping grout around conduits run through a pipe sleeve

DEPB - Direct Embed Pole Backfill - a lean concrete with a minimum strength of 1000 psi (6.9-MPa) at 28 days, for use as backfill around direct embed steel poles.

RFG - Rock with Fly Ash Grout - a two component backfill for direct embed steel and concrete poles; the initial component, RFG-Gravel, is a uniform size, coarse gravel. The gravel is placed by ready-mix truck in the annulus space of direct embedment poles. The second component, RFG-Grout is a flowable fly ash/cement/lime grout. The grout is batched separately and placed afterward, filling voids in the aggregate backfill by gravity flow (no pumping).

Each of these backfill materials has an SRP Material Stock Code Number (See Table 1). All references to these materials in purchase order documents, submittals and invoices shall use the SRP material stock code. Vendor may assign its own product codes in addition to those required by the Purchaser.

## 1.2 Reference Standards

1.2.1 Reference to standards and/or specifications herein shall be interpreted to mean the latest revision unless noted otherwise.

1.2.2 The following abbreviations appear in this Specification.

ACI	American Concrete Institute
ARPA	Arizona Rock Products Association
ASTM	American Society for Testing and Materials
NRCMA	National Ready-Mixed Concrete Association
SRP	Salt River Project

1.2.3 The following standards shall be made a part of this Specification.

ASTM C25	Standard Test Method for Chemical Analysis of Limestone, Quicklime and Hydrated Lime
ASTM C33	Standard Specification for Concrete Aggregates
ASTM C94	Standard Specification for Ready-Mixed Concrete
ASTM C117	Standard Test Method for Materials Finer Than 75-Micrometer (No. 200) Sieve in Mineral Aggregates by Washing

ASTM C136	Standard Method for Sieve Analysis of Fine and Coarse Aggregates
ASTM C143	Standard Test Method for Slump of Hydraulic Cement Concrete
ASTM C150	Standard Specification for Portland Cement
ASTM C172	Standard Practice for Sampling Freshly Mixed Concrete
ASTM C231	Standard Test Method for Air Content of Freshly Mixed Concrete by the Pressure Method
ASTM C260	Standard Specification for Air-Entraining Admixtures
ASTM C311	Standard Test Methods for Sampling and Testing Fly Ash or Natural Pozzolans for Use as a Mineral Admixture in Portland Cement Concrete
ASTM C403	Standard Test Method for Time of Setting of Concrete Mixtures by Penetration Resistance
ASTM C494	Standard Specifications for Chemical Admixtures for Concrete
ASTM C618	Standard Specification for Fly Ash and Raw or Calcined Natural Pozzolan for use as a Mineral Admixture in Portland Cement Concrete
ASTM C685	Standard Specification for Concrete Made by Volumetric Batching and Continuous Mixing
ASTM C937	Standard Specification for Grout Fluidifier for Preplaced-Aggregate Concrete
ASTM C939	Standard Test Method for Flow of Grout for Preplaced Concrete Aggregate (Flow Cone Method)
ASTM C1064	Standard Test Method for Temperature of Freshly Mixed Portland Cement Concrete
ASTM D512	Standard Test Methods for Chloride Ion in Water
ASTM D516	Standard Test Method for Sulphate Ion in Water

1 2.4 Exceptions to this specification must be approved in writing by the Engineer prior to commencement of the affected work.

**1 3 Definitions**

One Sack of cement same as one 94 pound (42.5-kg) bag of cement.

**1 4 Submittals**

**1 4 1 Vendor shall submit the following items for each material to be supplied**

- a Plant Certification
- b Mix designs
- c. Source and gradation of coarse and fine aggregate
- d. Cement certification and mill test report
- e Certification of testing of the water
- f. Fly ash certification
- g Admixture brand and source
- h. Lime certification and chemical analysis

**1.4 2 If the mix design and batch plant have been pre-approved by the Engineer, submittals under Section 1 4 1 will be waived.**

**1.4 3 Vendor shall refer to the mix designs by the SRP Material Stock Code Number**

**1 4 4 In addition to the specified materials, Vendors may submit alternate mix designs or deviations to the specifications for review and approval. The Engineer may request additional test and certification documentation for alternate mixes submitted.**

**1 5 Quality Assurance**

**1 5.1 Each plant from which the Vendor intends to provide materials governed by this specification must have current NRMCA, ARPA or equivalent laboratory certification**

**1 5 2 Vendor shall provide access to the plant for inspection of materials and/or batch plant equipment**

**1 6 Storage and Handling**

**1 6 1 All materials shall be stored and handled in such a manner as to prevent deterioration or intrusion of foreign matter and to produce a minimum amount of segregation**

**1 6 2 Storage of aggregate on a natural ground surface will be permitted if bottom 6 inches (152-mm) of pile is not used in batching**

**2.0 PRODUCT**



- 2.1 Cement
- Cement shall conform to ASTM C150, Type II with alkali content not to exceed 0.6 percent.
- 2.2 Fly Ash
- not deleteriously reactive with alkali in cement. Fly ash shall be sampled and tested in accordance with ASTM C311
- 2.3 Lime
- Lime shall be commercial dry hydrated lime containing a minimum 85 percent calcium hydroxide,  $\text{Ca(OH)}_2$ , as determined by ASTM C25. Lime shall be protected from exposure to moisture until used and shall be sufficiently dry and flow freely when handled.
- 2.4 Aggregate
- Aggregate shall conform to ASTM C33, coarse aggregate shall be sized as noted in Table 1 of this specification.
- 2.5 Water
- Water for washing aggregates and for mixing slurry shall be potable or shall meet requirements of ASTM C94. If water does not meet said requirements, a chemical analysis of water shall be performed in accordance with ASTM D512 and ASTM D516 by an independent testing laboratory at Vendor's expense and submitted to the Engineer for approval
- 2.6 Admixtures
- 2.6.1 Admixtures shall be approved in writing by the Engineer prior to use. Admixtures shall be added at the plant at the time of batching unless noted otherwise
- 2.6.2 Air-entraining admixtures shall conform to ASTM C260 and shall be used only in DEPB
- 2.6.3 Water-reducing, retarding, and accelerating admixtures shall conform to ASTM C494. Chloride admixtures shall not be used
- 2.6.4 Superplasticizers shall conform to ASTM C494, Type F or G Superplasticizer may be added at batch plant or at jobsite
- 2.6.5 Grout Fluidifiers shall conform to ASTM C937
- 2.7 Measurement and Mixing of Materials

- 2.7 1 Measurement and mixing of materials shall be in accordance with ASTM C94 and C685
- 2.7 2 Mixes shall be homogenous, readily placeable and uniformly workable. Proportioning of ingredients shall produce consistency, durability, workability and other required properties appropriate for the intended usage
- 2 8 Mix Design for RFG Grout
- 2 8 1 Proportioning of ingredients shall produce grout with efflux (flow consistency), set, strength and shrinkage characteristics as specified herein and appropriate for intended usage. Grout upon delivery shall be homogeneous, readily placeable and uniformly flowable.
- 2.8 2 Grout shall have an efflux time of less than 18 seconds for minimum 30 minutes after arrival at jobsite (tested in accordance with ASTM C939), shall be firm to the touch within 72 hours after placement, shall have no more than three percent volume loss (including fluid separation) seven days after batching and have a compressive strength when combined with aggregate of minimum 1000 psi (6.9-MPa) in 56 days. Mix shall maximize use of fly ash. General proportions for mix design are as follows.
- a Solids. 5 parts fly ash to 1 part cement to 3/4 part lime
  - b 2 1/4 parts solids to 1 part water
  - c. 20 ounces (0.6-L) of high-range water-reducing admixture per 100 pounds (45.2-kg) of solids
- Vendor is responsible for final mix design that meets performance requirements of this specification
- 2.8 3 Retarding admixtures may be added to mix to meet efflux requirements and compensate for travel time to specific jobsites. Volume of retarding agent added is responsibility of Vendor, but specific type must be preapproved by the Engineer prior to batching of grout.
- 2 8 4 No change in source, character or mix proportions of grout shall be made without prior written approval of the Engineer. For changes to be approved, affected items listed under Paragraph 1 4 1 shall be resubmitted
- 2 9 Batching RFG Grout
- 2 9 1 Mixing shall follow the procedures in ASTM C94, with all grout constituents added at the batch plant
- 2 9 2 Fly ash shall be added in a manner and at a rate as to minimize incompletely mixed fly ash nodules within the grout. Dry fly ash nodules over one inch

diameter shall not be allowed. Grout containing non-uniform material exceeding one percent of total grout volume, as determined by the Engineer, will be rejected at full cost to the Vendor

**2.10 Washed Gravel for RFG**

**2.10.1** Gravel shall be washed to remove dust and dirt prior to placement in mixer.

**2.10.2** Washed gravel shall be sent to jobsite by ready-mix truck. Maximum of two gallons (7.6-L) of water per cubic yard (0.84-m<sup>3</sup>) of gravel may be added.

**3.0 EXECUTION**

**3.1 Delivery**

**3.1.1** Deliver materials in conformance with ASTM C94

**3.1.2** When materials contain cement, machine-stamp batch out time of truck on delivery ticket at Vendor's plant. A copy of delivery ticket having machine-stamped batch out time shall be given to the Engineer at the time of delivery. Deliveries of materials containing cement without machine-stamped batch out time on delivery ticket will be rejected.

**3.1.3** Deliver materials within 30 minutes of requested delivery time. Time lapse between successive deliveries shall not vary by more than 20 minutes from that requested. The Engineer may reject any batch not meeting these requirements. Vendor shall allow 30 minutes for material discharge. Standby time may be charged after 30 minutes.

**3.1.4** Backfill containing cement will be rejected if the Engineer determines that, on arrival at the jobsite, backfill temperature is outside the range of 50°F (10°C) to 90°F (32°C), or that backfill has attained its initial set. Rejected backfill shall be at the Vendor's cost.

**3.1.5** Vendor may add water only once to bring a mix to the desired slump. Water shall not be added to RFG-Grout. Mix not meeting slump requirements will be rejected.

**3.2 Placement**

**3.2.1** Slurry and Lean Mix Backfills

Discharge backfill containing cement within 1-1/2 hours after initial mixing water is added. The Engineer may waive this limitation if slump is such that the material can be placed without addition of water.

Place backfill so that it flows easily around and beneath conduit, pipe or other obstructions in trenches and excavations. Slurry shall have consistency, workability, flow characteristics and pumpability (where required) such that the

material when placed is self-compacting and has sufficient plasticity that mechanical compaction or vibration is typically not required. Mechanical compaction or vibration may be used to consolidate around obstructions.

Place slurry backfill equally on both sides of conduit or pipe to prevent displacement of conduit or pipe.

Place slurry backfill in lift depths that will not float the conduit or pipe, to place backfill in greater lift depths, provide sufficient approved anchorage so the conduit or pipe cannot float.

### 3.2.2 Washed Gravel for RFG

Remove all excess water prior to placement of gravel by rotating mixer and directing water away from backfill area. Time for removal of excess water shall be at Vendor's cost. Wet gravel must flow uniformly and readily out of truck.

Gravel that has not been washed of dust and dirt will be rejected. Gravel that is not surface saturated shall not be placed.

### 3.2.3 RFG Grout

Discharge grout within 30 minutes after arrival at jobsite. This requirement may be waived by the Engineer if retarding admixtures are used.

Grout that exceeds efflux time requirements upon arrival at jobsite (as determined by flow testing), shall be rejected at full cost to Vendor. No water shall be added at jobsite or after batching to decrease efflux time.

## 3.3 Protection

3.3.1 Slurry backfill for trenches shall be protected from vehicular loading and shall not be covered with pavement prior to having reached initial set per ASTM C403, or for 12 hours, whichever occurs first. Set time tests shall be performed during initial placement while backfill is fluid.

3.3.2 Slurry backfill for foundation excavations shall be protected from foundation loading and placement of foundation concrete prior to having reached initial set per ASTM C403, or for six hours, whichever occurs first.

3.3.3 Where the Engineer has identified soils as being moisture sensitive, a drainage notch or drain wick shall be placed longitudinally along centerline of slurry backfill within first hour following placement. Drainage water shall be collected at end of trench or excavation and removed.

## 3.4 Testing

3 4 1 Samples will be taken directly from transit mix truck Sampling and testing will be in accordance with the following standards

Sampling	ASTM C172
Temperature	ASTM C1064
Slump	ASTM C143
Air	ASTM C231
Gradation	ASTM C117/ASTM C136

3 4 2 Testing of gradation shall be done for all projects in public rights-of-way and other locations as determined by the Engineer; sampling shall be done at material source prior to the start of mix production

3 4 3 Testing will be performed by the Engineer at no cost to Vendor

3 5 Acceptance of Backfill Materials

3 5.1 Backfill materials shall be considered deficient and will be rejected if  
a. slump is less than specified in table  
b. aggregate gradation is outside specified limits

3 5 2 Rejected material shall not be used and shall be replaced with new material. Cost of disposing of rejected material and replacing with new material, including Purchaser's direct and indirect costs, shall be paid by Vendor

TABLE 1 - BACKFILL MIXES

Stock Code Number	Backfill Designation	Description	Coarse Aggregate ASTM C33	Fine Aggregate	Slump Range	Minimum Cement Content (lbs/cu yd)	Required Admixtures
00-0100	ASB	Aggregate Slurry Backfill	No 67 [3/4" (19mm) nom max]	A, H	6"-9" (152-229mm)	None	
00-0101	DEPB	Direct Embed Pole Backfill	No 8 [3/8" (9.5mm) nom max]	A	6"-9" (152-229mm)	376 B (223 kg/m <sup>3</sup> )	C
00-0104	LMB 1/2 SACK	Lean Mix Backfill w/ 1/2 Sack Cement pcy	No 57 [1" (25mm) nom max]	A	6"-9" G (152-229mm)	47 (28 kg/m <sup>3</sup> )	
00-0105	LMB 1 SACK	Lean Mix Backfill w/ 1 Sack Cement pcy	No 57 [1" (25mm) nom max]	A	6"-9" G (152-229mm)	94 (56 kg/m <sup>3</sup> )	
00-0106	LMB 1-1/2 SACK	Lean Mix Backfill w/ 1-1/2 Sack Cement pcy	No 57 [1" (25mm) nom max]	A	6"-9" G (152-229mm)	141 (84 kg/m <sup>3</sup> )	
00-0108	DBA	Duct Bank Backfill w/ Large Aggregate	No 8 [3/8" (9.5mm) nom max]	A	6"-9" (152-229mm)	376 (223 kg/m <sup>3</sup> )	
00-0109	DBS	Duct Bank Backfill w/ Sand	None	A	6"-9" (152-229mm)	376 (223 kg/m <sup>3</sup> )	
00-0160	RFG GRAVEL	Washed Gravel for RFG	No 4 [1-1/2" (38.1mm) to 3/4" (19mm)]	None			
00-0161	RFG GROUT	Lime and Fly Ash Grout for RFG	None	None		D, E	F

- NOTES
- A Fine aggregates (sand) shall be in accordance with ASTM C33
  - B Maximum water/cement ratio 60
  - C Air entrainment 4% +/- 1%, Superplasticizers as required to obtain slump
  - D Cementitious solids 5 parts fly ash to 1 part cement to 3/4 part lime, by weight See paragraph 2 8 2
  - E Limit water content to 1 part water to 2 25 parts cementitious solids by weight See paragraph 2 8 8
  - F High range water reducing admixture
  - G Purchaser may request material at lower slumps
  - H Fine aggregates 45-50% of the total aggregate weight

SRP02227 PSE

SRP 02227  
10 of 10

**SALT RIVER PROJECT  
WATER GROUP**

**STANDARD SPECIFICATION  
FOR  
PRECAST CONCRETE PIPE  
(WTR 02614)**

**TABLE OF CONTENTS**

<b>SECTION</b>	<b>TITLE</b>	<b>PAGE</b>
1.0	GENERAL	1
1.1	Work Specified	1
1.2	Measurements	1
1.3	Reference Standards	1
1.4	Quality Assurance	3
1.5	Delivery, Storage and Handling	3
1.6	Warranty	4
2.0	PRODUCT	4
2.1	Type and Class of Pipe	4
2.2	Pipe Markings	4
2.3	Irrigation and Low Head Pressure Drain Pipe	4
2.4	Rubber Gasket Joints	5
2.5	Source Quality Control	5
2.6	Mortar/Grout	5
2.7	Pipe Diaper	5
2.8	Geotextiles	6
2.9	Bedding	6
2.10	Backfill	6
3.0	EXECUTION	7
3.1	Protection	7
3.2	Excavation	7
3.3	Subgrade	9
3.4	Bedding	10
3.5	Pipe Installation	10
3.6	Backfilling	14
3.7	Field Test	16
3.8	Cleanup	16

PREPARED: CHARLES W. THUMS

APPROVED: 

**STANDARD SPECIFICATION**  
**FOR**  
**PRECAST CONCRETE PIPE**  
(WTR 02614)

1.0 **GENERAL**

1.1 Work Specified

This specification covers the fabrication, furnishing and installation of precast concrete pipe.

1.2 Measurements

Both English and metric measurements are shown in this specification. The English and metric measurements shown may not be exactly equal, however, the difference between them will generally be between +/- 1.5%. The system of measurement to be used relative to this specification for a particular project will be that used in the project-specific documents and drawings.

1.3 Reference Standards

1.3.1 Reference to standards or specifications shall be interpreted to mean the latest revision unless noted otherwise.

1.3.2 The following abbreviations appear in this specification.

ASTM	American Society for Testing and Materials
CE	Civil Engineering
OSHA	Occupational Safety and Health Administration
SRP	Salt River Project
29 CFR	Code of Federal Regulations, Title 29

1.3.3 The following standards shall be made a part of this specification:

ASTM C14	Standard Specification for Concrete Sewer, Storm Drain, and Culvert Pipe (reference only - for hydrostatic testing of ASTM C76 pipe)
----------	--



ASTM C76	Standard Specification for Reinforced Concrete Culvert, Storm Drain, and Sewer Pipe
ASTM C144	Standard Specification for Aggregate for Masonry Mortar
ASTM C150	Standard Specification for Portland Cement
ASTM C207	Standard Specification for Hydrated Lime for Masonry Purposes
ASTM C309	Standard Specification for Liquid Membrane-Forming Compounds for Curing Concrete
ASTM C361	Standard Specification for Reinforced Concrete Low-Head Pressure Pipe
ASTM C443	Standard Specification for Joints for Circular Concrete Sewer and Culvert Pipe, Using Rubber Gaskets
ASTM C507	Standard Specification for Reinforced Concrete Elliptical Culvert, Storm Drain, and Sewer Pipe
ASTM C822	Standard Terminology Relating to Concrete Pipe and Related Products
ASTM D698	Test Method for Laboratory Compaction Characteristics of Soil Using Standard Effort (Standard Proctor)
ASTM C924	Standard Practice for Testing Concrete Pipe Sewer Lines by Low-Pressure Air Test Method
ASTM C969	Standard Practice for Infiltration and Exfiltration Acceptance Testing of Installed Precast Concrete Pipe Sewer Lines
ASTM C1103	Standard Practice for Joint Acceptance Testing of Installed Precast Concrete Pipe Sewer Lines

SRP 02227		Salt River Project Standard Specification for Slurry Backfill Materials
SRP 02230		Salt River Project Standard Specification for Aggregate Base, Select Material and Surface Material
CE 02.272		Salt River Project Standard Specification for Geotextiles
OSHA		General Industry Occupational Safety and Health Standards (29 CFR Part 1910)
OSHA		Safety and Health Standards for Construction (29 CFR Part 1926)
SRP	ESRM	Salt River Project Excavation Safety Resource Manual

1.3.4 Exceptions to this specification require approval in writing by the Engineer prior to beginning the affected work.

#### 1.4 Quality Assurance

As part of purchase agreement for pipe, Contractor shall stipulate that the Engineer shall have access to the following:

- a. Pipe manufacturing specifications.
- b. Certification of pipe by others.
- c. Pipe manufacturing quality control test results.
- d. Manufacturing facilities to observe manufacture of pipe.
- e. Testing facilities to observe testing of materials and pipe.

#### 1.5 Delivery, Storage and Handling

1.5.1 Notify the Engineer of name and address of pipe seller a minimum of two working days before delivery of pipe.

1.5.2 Deliver only requested quantity of pipe to jobsite. Delivery of greater or lesser quantity of pipe requires advance approval of the Engineer.

1.5.3 Provide copy of D-load test documentation along with delivery for each production lot of pipe included in that delivery. Pipe shall not be installed if copy of D-load test information for that particular production lot/date is not available on site.

1.5.4 Integrity of pipe is responsibility of seller until pipe has been delivered and unloaded at jobsite. Contractor is responsible for protecting pipe from physical damage or loss after delivery at jobsite until acceptance of the Work by the Engineer.

#### 1.6 Warranty

Contractor shall warranty material and workmanship for a period of one year from date of written final acceptance of pipeline by the Engineer; leaks, defects and deterioration shall be repaired/replaced at no cost to SRP. Contractor shall make repairs/replacements within 14 days, or if dry-up is required, during first available dry-up following notification of leak or deficiency.

### 2.0 PRODUCT

#### 2.1 Type and Class of Pipe

Type and class of pipe required for project will be stated in project-specific specifications or shown on drawings.

#### 2.2 Pipe Markings

Pipe shall be marked as required by the applicable ASTM specification.

#### 2.3 Irrigation and Low Head Pressure Drain Pipe

2.3.1 Rubber gasketed reinforced concrete pipe (RGRCP) shall meet one of the following requirements:

- a. ASTM C361 and withstand minimum 10 PSI (70 kPa) hydrostatic test pressure.
- b. ASTM C76, class III, wall B and meet hydrostatic test requirements as specified in ASTM C14.

2.3.2 Reinforced concrete elliptical pipe (RCEP) shall meet requirements of ASTM C507 and withstand minimum 10 PSI (70 kPa) hydrostatic test pressure as specified in hydrostatic testing requirements of ASTM C361.

2.3.3 Premanufactured bend shall meet requirements of specification for type of pipe with which it is to be

5/08/97

used. Maximum angle of bend shall not exceed that shown on drawings. Premanufactured bends shall be manufactured in accordance with approved shop drawings; submit shop drawings to the Engineer for approval minimum two weeks prior to manufacture of bend.

#### 2.4 Rubber Gasket Joints

2.4.1 Rubber gasket joints shall meet requirements of ASTM C443.

2.4.2 When pipe is supplied with gasket installed, gasket end of pipe shall be enclosed in weathertight protective covering.

#### 2.5 Source Quality Control

2.5.1 External load crushing strength tests shall be in accordance with ASTM standard under which pipe was manufactured.

2.5.2 Pipe tests shall be performed at no cost to SRP at either pipe manufacturer's plant or at an independent testing facility acceptable to the Engineer.

#### 2.6 Mortar/Grout

Mortar for repair of precast concrete pipe shall be composed of two parts sand to one part portland cement (by volume) and sufficient water to provide a plastic mixture.

Up to one-fifth part hydrated lime may be added to adjust consistency of mix. Lime shall be in addition to and not a replacement for cement. Equal or similar mortar may be substituted with prior approval of the Engineer.

- a. Sand (aggregate) shall conform to requirements of ASTM C144.
- b. Portland cement shall conform to requirements of ASTM C150, Type II.
- c. Hydrated lime shall conform to requirements of ASTM C207, type N.

#### 2.7 Pipe Diaper

Pipe diaper shall be made of Typar or other suitable fabric having porosity low enough to prevent loss of cement from grout. Edges of fabric shall be hemmed; steel strapping bands for securing diaper around pipe shall be sewn into outside edges of diaper.

2.8 Geotextiles

Geotextiles used to stabilize subgrade shall conform to requirements of CE 02.272.

2.9 Bedding

Granular fill used for Class C or better bedding shall be processed aggregate base material (ABC) meeting requirements of SRP 02230.

2.10 Backfill

2.10.1 Native material used for backfill shall meet following particle size requirements:

- a. Maximum 50 percent (by weight) retained on 3/4" (19 mm) sieve.
- b. From bedding to finish grade, native backfill shall not contain solid material exceeding three inches (75 mm) in greatest dimension or exceeding 1/3 distance between side of pipe and trench wall.

Suitability of native material for use as backfill for specific project will be determined by the Engineer.

2.10.2 Granular backfill material shall be processed aggregate base material (ABC) meeting requirements of SRP 02230.

2.10.3 Aggregate slurry backfill shall be processed (washed) aggregate base material (ABC) in slurry form meeting requirements of SRP 02227.

2.10.4 Lean mix backfill shall meet requirements of SRP 02227.

2.10.5 Unsuitable backfill materials include, but are not limited to, the following:

- a. Silt and clay soils which have moisture content significantly over optimum or which cannot be compacted to required density.
- b. Expansive soils.
- c. Sod, matted or decayed vegetation.
- d. Deleterious materials.

### 3.0 EXECUTION

#### 3.1 Protection

3.1.1 Cost of excavation protection shall be included in excavation bid price.

3.1.2 Protect excavation and safeguard personnel as required for safety and conformance to governing law, including OSHA standards and SRP ESRM. The Engineer reserves the right to stop work deemed unsafe until unsafe condition is corrected by Contractor.

3.1.3 Maintain underground and overhead utilities in continuous service unless prior approval to interrupt service has been obtained from the Engineer. Locate conflicting utilities shown on drawings and identified in field. Comply with Blue Stake requirements for locating all utilities. Contractor shall be responsible for locating, protecting and repairing private lines. Pothole for true depths. Relocate conflicting utilities to resolve conflicts. Utilities identified before excavation and subsequently damaged by Contractor shall be repaired at Contractor's expense.

3.1.4 Contractor shall protect against and shall be liable for damage to buildings, foundations and structures.

3.1.5 Keep pipe trench free of water. Berm or otherwise protect trench from surface drainage and runoff. Failure to protect trench is not grounds for extension of irrigation outage.

3.1.6 Provide safe and convenient passage for pedestrians and vehicles. Maintain access to hospitals, fire stations, and fire hydrants at all times. Barricade or bridge trenches at end of day's work as specified by governing municipality/agency. The Engineer may designate additional points at which passage shall be provided.

3.1.7 Remove excess material from jobsite within 48 hours after backfilling trench. See paragraph 3.8.1 for disposal requirements. Treat loose material to control dust and to prevent pollution of runoff water as specified by governing municipality/agency.

#### 3.2 Excavation

3.2.1 Comply with open trench length requirements of governing municipality/agency.

3.2.2 Alignments and elevations will be surveyed and staked by SRP, unless noted otherwise. Contractor shall

be responsible for protecting stakes. Restaking shall be at Contractor's expense.

3.2.3 Excavations shall conform to alignments, elevations, dimensions and tolerances indicated on drawings or in specifications. Do not begin excavation before establishment of alignments and elevations.

3.2.4 Trench width shall be as specified in Table 1 unless otherwise indicated on drawings or in project-specific specifications. Written approval of the Engineer is required prior to substitution of other pipe or bedding for that specified. From one foot (300 mm) above top of pipe, trench may be widened as necessary to accommodate sheeting, bracing and proper installation of pipe.

<b>Size of Pipe (ID)</b>	<b>Maximum Width at Top of Pipe (Add to Barrel OD)</b>	<b>Minimum Width at Springline (Each Side of Pipe)</b>
Less than 18 in (450 mm)	16 in. (400 mm)	6 in. (150 mm)
18 in. to 24 in. (450-600 mm) inclusive	19 in. (475 mm)	8 in. (200 mm)
27 in. to 39 in. (675-975 mm) inclusive	22 in. (550 mm)	9 in. (225 mm)
42 in. to 60 in. (1050-1500 mm)	1/2 OD	12 in. (300 mm)
Over 60 in. (1500 mm)	36 in. (900 mm)	12 in. (300 mm)

3.2.5 When backfill below springline of pipe is to be mechanically compacted, minimum distance from all points on pipe at springline to edge of trench shall be width of compaction shoe plus two inches (50 mm).

3.2.6 When backfill from bottom of trench to springline or above is to be aggregate slurry, minimum distance from pipe at springline to edge of trench shall be three inches (75 mm).

3.2.7 Trench bottom shall be level for full width; remove, or fill and compact tooth marks greater than two inches (50 mm) deep. In rock, bottom of trench shall be overexcavated minimum six inches (150 mm) and filled with granular bedding material to provide smooth surface; compact granular bedding material for full width of trench to requirements shown on drawings.

3.2.8 Excavation carried beyond dimensions or elevations indicated on drawings without the Engineer's approval, shall be backfilled and compacted as directed by the Engineer at Contractor's expense.

### 3.3 Subgrade

3.3.1 Existing subgrade material and subgrade fill material shall be compacted to a minimum of 85 percent of maximum density and moisture content shall be between four percent below and two percent above optimum moisture content as determined per ASTM D698, unless noted otherwise in specifications or drawings.

3.3.2 Suitability of subgrade will be determined by the Engineer prior to placement of bedding.

3.3.3 Unsuitable subgrade materials include, but are not limited to, the following:

- a. Silt and clay soils which have moisture content significantly over optimum or which cannot be compacted to required density.
- b. Expansive soils.
- c. Sod, matted or decayed vegetation.
- d. Deleterious materials.

3.3.4 Treatment of existing subgrade material which exceeds optimum moisture content by more than two percent must be approved by the Engineer. Method of treatment shall be submitted in writing to the Engineer for approval.

3.3.5 Remove unsuitable materials, soil that cannot be dried to meet moisture content specified in paragraph 3.3.1 and soil that cannot attain a maximum dry density of 85 percent. Overexcavate trench minimum two feet (600 mm) each side of pipe bell at springline and maximum four feet (1200 mm) below elevation indicated on drawings, or to suitable subgrade, whichever occurs first. Dispose of removed material in accordance with paragraph 3.8.1. Fill overexcavation with granular material (ABC) to grade indicated on drawings and compact to 95 percent of optimum density per ASTM D698.

3.3.6 Subgrade soils which are unsuitable only because of high moisture content may be left in place and stabilized using geotextiles, if approved by the Engineer. Geotextile shall comply with requirements of CE 02.272. Subgrade preparation, placement of geotextiles, and



placement and compaction of fill material shall be in accordance with geotextile manufacturer's recommendations.

### 3.4 Bedding

3.4.1 Bedding requirements shall be as called for on drawings. Class C bedding or better is required unless otherwise specified on drawings, on license or in project-specific specifications.

3.4.2 Remove loose material, rocks, deleterious material, and debris from trench bottom prior to placing bedding material.

3.4.3 Bedding material shall be at a uniform moisture content of between optimum and five percent above optimum; compact to density required in 3.6.3 Compaction in one foot (300 mm) or smaller uncompacted lifts.

3.4.4 Finish and compact bedding to elevation indicated on drawings; assure that bedding will provide continuous support for pipe.

3.4.5 Excavate bell holes with minimum two inch (50 mm) clearance to prevent point loading of laid pipe and to maintain continuous support of pipe barrel. Excavate cable holes to prevent movement of pipe when removing sling.

3.4.6 Added or disturbed bedding material shall be compacted to densities required in 3.6.3. Compaction.

### 3.5 Pipe Installation

#### 3.5.1 General

- a. Install pipe to alignment and elevation shown on drawings. Variation from indicated alignment and elevation shall not exceed 0.1 foot (30 mm), and the rate of departure from or return to indicated alignment and elevation shall be no more than 0.1 foot (30 mm) in ten feet (3000 mm), unless otherwise approved by the Engineer. Bends shall be within one-half pipe section of station shown on drawings. All changes in station require prior approval of the Engineer. Contractor shall mark approved changes in stationing, based on measurement of installed pipe, on drawings and shall supply marked drawings to the Engineer.
- b. Lay pipeline with minimum horizontal separation of two feet (600 mm) from parallel utilities and with minimum one foot (300 mm)

vertical separation from utilities which cross below pipeline. No overcrossings of SRP irrigation pipe will be allowed without approval of the Engineer. Notify the Engineer immediately if it is found that a utility will be closer to pipeline than specified minimum separation.

- c. Install elliptical pipe and elliptically reinforced pipe with vertical axis within ten degrees of true vertical.
- d. Gaps in pipeline during installation due to utility conflicts will not be allowed unless otherwise approved by the Engineer.

### 3.5.2 Joint Assembly

- a. Rubber gasketed joints (C76 and C361 pipe): Lay pipe with bell ends facing in direction of laying unless otherwise approved by the Engineer. Begin laying pipe at lower end of slope and proceed upward on grades which exceed ten percent. Only use gaskets and lubricant supplied by pipe seller. Clean joint mating surfaces and gasket before joining pipes. Apply generous, uniform coating of gasket lubricant to inside surface of bell end of pipe, in groove portion of spigot, and on gasket. Install gasket in accordance with pipe seller's instructions. Keep joint from contacting ground when inserting pipe spigot into bell. Use industry approved methods to push or pull pipe to complete joint closure.
- b. Tongue and groove mortar joints (C507 pipe): Clean joint mating surfaces prior to joining pipes. Thoroughly wet tongue and groove with water and keep moist until mortar is placed; use brush to apply water. Apply mortar to upper half of tongue and to bottom half of groove in a manner which will fill entire joint. Use industry approved methods to push or pull pipe into position until mortar is squeezed from both inside and outside of joint. Adjust pipe to design alignment and grade; secure pipe section firmly in position using a small amount of bedding material placed and tamped thoroughly against lower portion of pipe at midpoint of length. Remove excess mortar from interior joint and finish interior joint recess smooth and flush with inside of pipe; remove all debris.

If adjustment of position of pipe is required after it has been laid, remove pipe, clean and rejoin it.

Keep the finishing of exterior joints between five and two sections of pipe behind pipe laying operations. Complete outside of joint by covering with hand-placed mortar band extending completely around outside of pipe. As soon as mortar band has set sufficiently, coat it with white-pigmented curing compound conforming to ASTM C309, Type 2, Class A, or provide a suitable moist cure acceptable to the Engineer.

- c. Pipe diaper joints: Grout bands may be placed by diapering when specifically authorized by the Engineer.

After joining pipe, center and secure diaper over the exterior joint recess. Diaper shall completely and snugly encase the exterior joint except for an opening at the top; width of diaper is governed by size of pipe. Moisten joint recess with water prior to grout placement. Form grout band around pipe by pumping grout into opening of diaper; pump grout to one side of pipe until it flows completely under bottom of pipe and partially up other side, then pump to opposite side to fill diaper and complete grout band. Close opening in diaper. Keep grout band moist until trench is backfilled and band is covered.

### 3.5.3 Radius Curves

- a. Gasketed joints: Long radius curves shall be made by using pipe manufactured with beveled ends or by pulling pipe joints of straight sections of pipe (deflecting pipe unit from straight alignment by opening one side of the outside perimeter of the joint wider than the other side) as it is laid. Maximum opening of pulled joint is  $\frac{1}{2}$ " (13 mm) wider than width of joint when pipe is assembled in straight alignment. Deflections requiring outside joint to be pulled more than  $\frac{1}{2}$ " (13 mm) shall be considered to be field bends.
- b. Field bends and grade changes: Use reinforced pipe collar to make joints at field bends up to and including 45° (degrees) and grade changes.

Collar for reinforced concrete pipe shall be of mechanically compacted, reinforced, minimum 3000 psi (20 MPa) concrete. Outside of collar shall be made by forming; inside of collar shall conform to inside diameter of pipe. Maintain full pipe cross-section and smoothness through length of bend or grade change. Ensure that forming material is completely removed from inside pipe.

- c. Precast Bends: Shall be as shown on drawings. Submit shop drawings of precast bends to the Engineer for approval; approval of the Engineer is required before beginning fabrication of precast bends.

#### 3.5.4 Branch Connections

Type, size, location and angle of branch connections for irrigation pipe will be shown on drawings. Shop drawings are required for all pre-fabricated connections; submit shop drawings for approval of the Engineer.

#### 3.5.5 Repairs

- a. Repair tie holes, minor cracks and depressions in pipe surface with cement based, rapid setting mortar such as Speed Crete 2028 (Tammis Industries Co.) or approved equal. Clean and moisten surface before applying mortar.
- b. If new or existing pipe has 0.01 inch (0.3 mm) or wider crack(s) notify the Engineer and request inspection of the pipe.

Repair 0.01 inch (0.3 mm) or wider cracks in an otherwise acceptable section of pipe with epoxy grout approved by the Engineer. V-groove inside cracks minimum 1/4 inch (6 mm) deep. Clean area prior to repair.

If crack goes through pipe wall or if structural integrity of pipe is in question, the Engineer may, at his option, require removal of damaged pipe and replacement with new.

- c. Finished surface of inside repairs shall be smooth and flush with inside pipe surface.
- d. Repairs shall not reduce inside pipe diameter.

### 3.5.6 Plugs

- a. Temporarily cover or plug installed piping systems each day at end of work. Covers or plugs shall prevent entry of persons, small animals or deleterious material into pipe.
- b. Completely remove all temporary covers, plugs, caps or dikes installed during construction before completion of construction.

### 3.6 Backfilling

#### 3.6.1 General

- a. Unless otherwise noted on drawings or in project-specific specifications, backfill shall be as noted in 2.10 Backfill.
- b. Moisture content of backfill shall be as noted in paragraph 3.6.2.
- c. Do not disturb or damage pipe when backfilling trenches. Place backfill evenly on opposite sides of pipe to prevent movement of pipe.
- d. Lift thickness shall not exceed that which can be effectively compacted by type of equipment and method used. Maximum uncompacted lift thickness for processed or native granular material shall be limited to one foot (300 mm); maximum uncompacted lift thickness for non-granular native material shall be limited to eight inches (200 mm). Do not allow mechanical compaction equipment to come into direct contact with pipe.
- e. Place and consolidate lean mix backfill and aggregate slurry backfill in lift depths that will not cause pipe to move or float. Discharge backfill directly from mixer into trench with even distribution on opposite sides of pipe. Backfill shall flow freely and uniformly around and under pipe without leaving voids; vibrate backfill to consolidate when slump is less than six inches (150 mm) or whenever required to fill voids.

#### 3.6.2 Moisture Content

- a. Contractor shall have sole responsibility to control moisture content of backfill. Optimum moisture content of backfill shall be determined in accordance with ASTM D698. Moisture

content which is outside of range specified shall be sufficient cause to require removal of placed backfill.

- b. Moisture condition backfill material before placement, unless otherwise approved by the Engineer.
- c. Place granular material, except for aggregate slurry, at a uniform moisture content of between optimum and three percent above optimum.
- d. Place aggregate slurry with water content as specified in SRP 02227. The Engineer may require increase or decrease in water content to obtain desired slump.
- e. Place native material, which does not meet requirements for classification as granular material, at a uniform moisture content of between three percent below to two percent above optimum.

### 3.6.3 Compaction

Compact or consolidate bedding and backfill to, at minimum, density specified in Table 2. Where conflicting density requirements exist, use highest density. Test density in accordance with ASTM D698. Bedding or backfill not meeting density requirements shall be removed/reworked at Contractor's expense.

### 3.6.4 Field Quality Control

- a. Inspection and compaction tests are required on trench backfill. Compaction tests are not required on lean mix backfill meeting requirements of SRP 02227.
- b. The Engineer will verify density and moisture content of bedding and backfill material during construction. Tests will be made at discretion of the Engineer.
- c. Backfill lifts shall not be covered before compaction tests are performed. If lift is covered prior to testing, Contractor is at own risk and shall excavate test holes for making density tests on lower portions of backfill at instruction of the Engineer. Refill and compact test holes in accordance with specifications. Excavating, refilling and compacting test holes shall be at Contractor's expense.

TABLE 2				
Compaction Type	Location	From Surface to 2' (600 mm) Below Surface	From 2' (600 mm) Below Surface to 1' (300 mm) Above Top of Pipe	From 1' (300 mm) Above Top of Pipe to Bottom of Trench
I	Under any existing or proposed pavement, curb, gutter, sidewalk, or such construction included in the contract, or when any part of the trench excavation is within 2' (600 mm) of the above	100% for granular, 95% for non-granular	90%	90%
II	On any utility easement, street, road or alley right-of-way outside limits of (I).	85%	85%	90%
III	Around any structures or exposed utilities.	95%	95%	95%

### 3.7 Field Test

3.7.1 The Engineer may, at his option, require Contractor to test integrity of installed pipeline or joints. Pipeline and joint tests shall be made at Contractor's expense. The Engineer will monitor field testing.

3.7.2 Pipeline tests shall be in accordance with ASTM C969. Test pressure shall correspond to maximum operating head condition stipulated by SRP Watermaster responsible for that area. Test period shall be 24 hours. The availability of water for pipeline field tests is entirely at the option and convenience of SRP.

3.7.3 Joint tests shall be in accordance with ASTM C924 for 24" (600 mm) pipe or smaller and ASTM C1103 for 27" (675 mm) pipe or larger.

3.7.4 Contractor shall repair all deficiencies revealed by field testing. Tests shall be successfully completed prior to final acceptance of the pipeline.

### 3.8 Cleanup

3.8.1 Remove unsuitable material and excess spoil material from jobsite and dispose of at SRP approved disposal site, unless otherwise directed by the Engineer. Removal and disposal of material shall be at Contractor's expense.

5/08/97

3.8.2 Dress grades adjacent to the work as needed to return site to like original condition, unless otherwise directed by the Engineer.

3.8.3 All work and property of SRP and/or others damaged or destroyed by Contractor, its employees or Subcontractors shall be repaired or replaced at Contractor's expense to the satisfaction of the Engineer.



SALT RIVER PROJECT  
STANDARD SPECIFICATION  
 FOR  
REINFORCING STEEL  
 (SRP 03210)

TABLE OF CONTENTS

SECTION	TITLE	PAGE
1 0	GENERAL	1
1 1	Work Specified	1
1 2	Work Performed by Purchaser	1
1.3	Standard Units	1
1 4	Reference Standards	1
1 5	Submittals	2
1.6	Storage and Handling	3
2 0	PRODUCT	3
2.1	Reinforcing Steel	3
2 2	Bar Supports	4
2 3	Specialty Items	4
2 4	Drawing Requirements	4
2.5	Fabrication	5
2.6	Quality Assurance	5
3 0	EXECUTION	5
	None	

PREPARED BY K L CHHIBBER

APPROVED BY L. A. BOTTOLFSON

REVISED BY K. L. CHHIBBER 

APPROVED BY L. A. BOTTOLFSON 

STANDARD SPECIFICATION  
FOR  
REINFORCING STEEL  
(SRP 03210)

1 0 GENERAL

1.1 Work Specified

This Specification covers the furnishing of all shop drawings, plant, labor, materials, tools, equipment and performing all operations and incidentals necessary for supplying reinforcing steel, plain steel dowels and bar supports

1.2 Work Performed by Purchaser

When construction work is performed by Purchaser, the term Contractor shall mean the reinforcing steel supplier.

1 3 Standard Units

Either English or SI (metric) units may be used. Whichever units are specified on the drawings shall be considered standard for that project. Substitution between English and SI products will be allowed, provided that at least equivalent cross-sectional area is furnished.

1.4 Reference Standards

1 4.1 Reference to standards or specifications shall be interpreted to mean the latest revision unless otherwise noted

1.4.2 The following abbreviations appear in this Specification:

ACI	American Concrete Institute
ASTM	American Society for Testing and Material
CRSI	Concrete Reinforcing Steel Institute

1 4 3 The following standards shall be made a part of this Specification

ACI 315	Details and Detailing of Concrete Reinforcement
---------	---

ACI 318/318M	Building Code Requirements for Reinforced Concrete
ACI SP-66	ACI Detailing Manual
ASTM A36/A36M	Standard Specification for Carbon Structural Steel
ASTM A82	Standard Specification for Steel Wire, Plain, for Concrete Reinforcement
ASTM A185	Standard Specification for Steel Welded Wire Fabric, Plain for Concrete Reinforcement
ASTM A615/ A615M	Standard Specification for Deformed and Plain Billet-Steel Bars for Concrete Reinforcement
ASTM A775/ A775M	Standard Specification for Epoxy-Coated Reinforcing Steel Bars
CRSI Handbook	Concrete Reinforcing Steel Institute Handbook

1.4.4 Exceptions to this Specification must be approved in writing by the Engineer prior to beginning the affected work

#### 1.5 Submittals

##### 1.5.1 Shop Drawings

- a. Two prints of each shop drawing shall be submitted to the Engineer for review and approval. The Engineer will require at least three working days for review of shop drawings.
- b. Shop drawings shall include placement drawings, bar list, bending details, standees and spreader bars, and schedules for fabrication and delivery of reinforcing steel.
- c. Shop drawings shall be checked and signed prior to submittal.
- d. The Engineer will return one print of each shop drawing marked "Approved", "Approved as Noted", or "Not Approved". Submittals that are marked "Approved as Noted" or "Not Approved" shall be corrected and resubmitted. Each revision shall be dated.

- e. The Engineer's approval of submittals shall not relieve Contractor from responsibility for compliance with Drawings, Specifications and other Contract Documents nor from responsibility for errors in submittals.
- f. Fabrication shall not begin until all shop drawings are approved by the Engineer
- g. *Four sets of prints and one vellum of each final approved shop drawing shall be provided to the Engineer. The Engineer will distribute shop drawings to jobsite Foreman and Inspector when construction work is performed by Purchaser.*

1.5.2 Two copies of original material manufacturer's Material Test Reports (MTR) for reinforcing steel shall be submitted to the Engineer prior to shipment.

1.5.3 Two copies of manufacturer's catalog data for each splicing device or other specialty item shall be submitted to the Engineer prior to shipment

## 1.6 Storage and Handling

1.6.1 Reinforcing steel shall be protected during shipping and unloading to prevent damage to material or loss of identification tags.

1.6.2 Reinforcing steel shall be stored above grade and in such a manner as to prevent contamination with dirt, rust, oil or other bond-breaking coatings

1.6.3 Damaged, misfabricated or deteriorated materials, not caused by Purchaser's actions, shall be replaced by Contractor at no additional cost to Purchaser

## 2.0 PRODUCT

### 2.1 Reinforcing Steel

2.1.1 All reinforcing steel shall comply with the following standards:

- a. Bars shall conform to ASTM A615, Grade 60 (ASTM A615M, Grade 400) unless noted otherwise
- b. Epoxy-coated bars shall conform to ASTM A775/A775M

- c. Plain steel wire reinforcement shall conform to ASTM A82.
- d. Plain steel welded wire fabric shall conform to ASTM A185
- e. Plain steel dowels shall conform to ASTM A36/A36M.

2 1.2 All material shall be new and free from loose rust, loose mill scale, dirt, oil and paint.

2 1.3 Reinforcing steel with tightly adhered mill scale or rust or a combination of both will be acceptable provided the minimum dimensions (including deformations) and weight of a hand wire-brushed test specimen are not less than acceptable ASTM requirements.

## 2.2 Bar Supports

2 2.1 Chairs and bolsters shall be steel, plastic or concrete, and shall be of size and dimensions necessary to perform required function

2 2.2 Standees shall be furnished with the reinforcing steel when top and bottom mats in slabs are shown on the drawings. Maximum standee spacing shall be 4 feet (1200 mm) each way.

2.2.3 Spreader bars shall be furnished with the reinforcing steel when reinforcing in both faces of walls is shown on the drawings and the concrete pour height in such walls exceeds 8 feet (2400 mm). Maximum spreader bar spacing shall be 4 feet (1200 mm) each way

## 2.3 Specialty Items

Materials not specifically described, but required for complete and proper installation of reinforcing steel, shall be approved by the Engineer prior to use

## 2.4 Drawing Requirements

2 4.1 All placement drawings shall have a clear area within the border in lower right corner for Purchaser's drawing number to be affixed by the Engineer

2 4.2 Letters, figures and line work on reproducibles shall be clear and dense enough to reproduce legibly on prints. Background shall be free of blemishes which would show on reproduction

2.4.3 Drawings and data shall be in sufficient detail to indicate the type, size, arrangement and weight of each component.

## 2.5 Fabrication

2.5.1 All reinforcing steel shall be shop fabricated in accordance with approved shop drawings.

2.5.2 All bars shall be bent cold.

2.5.3 Welding reinforcing steel will not be allowed

2.5.4 Fabrication details and tolerances shall comply with requirements of ACI 315.

## 2.6 Quality Assurance

2.6.1 All material shall be subject to inspection by the Engineer. Materials not meeting the requirements of this Specification will be rejected. Reinforcing steel may be rejected at fabrication plant or at jobsite. The Contractor shall be responsible for all Purchaser's direct and indirect costs for removal and replacement of rejected reinforcing steel. Inspection may be waived by the Engineer but such waiver shall not be interpreted as releasing Contractor from responsibility for delivery of materials conforming to this Specification.

2.6.2 Each bundle shall be tagged with quantity, bar size, and piece mark in accordance with approved shop drawings. A complete shipping list shall be provided for each shipment. Failure of Contractor to comply with these requirements will result in rejection of the shipment.

## 3.0 EXECUTION

None

SALT RIVER PROJECT  
STANDARD SPECIFICATION  
 FOR  
CONCRETE  
 (SRP 03300)

TABLE OF CONTENTS

SECTION	TITLE	PAGE
<b>1.0</b>	<b>GENERAL</b>	<b>1</b>
1.1	Work Specified	1
1.2	Work Performed by Concrete Supplier	1
1.3	Standard Units	1
1.4	Reference Standards	1
1.5	Submittals	5
1.6	Quality Assurance	8
1.7	Storage and Handling	9
<b>2.0</b>	<b>PRODUCT</b>	<b>9</b>
2.1	Cement	9
2.2	Aggregate	9
2.3	Water	9
2.4	Admixtures	9
2.5	Fly Ash	11
2.6	Proportioning of Mix	11
2.7	Measuring Materials	12
2.8	Mixing	12
2.9	Delivery and Batch Ticket	13
2.10	Hot Weather Concreting	14
2.11	Cold Weather Concreting	14
2.12	Direct and Indirect Costs	14
<b>3.0</b>	<b>EXECUTION</b>	<b>14</b>
3.1	Placement	14
3.2	Testing, Strength Compliance and Acceptance of Concrete	15
	<b>Table 1: SRP Standard Concrete Mixes (6-30-2018)</b>	<b>19</b>

REVISED: J. ADAMS

APPROVED: K. L. CHHIBBER

STANDARD SPECIFICATION  
FOR  
CONCRETE  
(SRP 03300)

1.0 GENERAL

1.1 Work Specified

This specification covers the furnishing of all plant, labor, materials and equipment necessary for designing, mixing, and delivering normal and light weight Portland cement concrete ready for placement.

1.2 Work Performed by Concrete Supplier

Concrete Supplier is defined as the concrete supplier responsible for designing, proportioning, mixing, and delivering Portland cement concrete. Concrete will be requested either by the Buyer, or by the Contractor retained by the Buyer.

1.3 Standard Units

English units are the standard.

1.4 Reference Standards

1.4.1 Reference to standards or specifications shall be interpreted to mean the latest revision unless noted otherwise.

1.4.2 The following abbreviations appear in this Specification:

ACI	American Concrete Institute
ADEQ	Arizona Department of Environmental Quality
ARPA	Arizona Rock Products Association
ASTM	American Society for Testing and Materials
EPA	U.S. Environmental Protection Agency
ICC	International Code Council
MAG	Maricopa Association of Governments
NRMCA	National Ready-Mixed Concrete Association



## SRP                      Salt River Project

## 1.4.3 The following standards and reports shall be made a part of this Specification:

ACI 212.3R	Report on Chemical Admixtures for Concrete
ACI 304R	Guide for Measuring, Mixing, Transporting, and Placing Concrete
ACI 305.1	Specification for Hot Weather Concreting
ACI 306.1	Standard Specification for Cold Weather Concreting
ACI 318	Building Code Requirements for Reinforced Concrete
ASTM C31	Standard Practice for Making and Curing Test Specimens in the Field
ASTM C25	Standard Test Method for Chemical Analysis of Limestone, Quicklime and Hydrated Lime
ASTM C33	Standard Specification for Concrete Aggregates
ASTM C39	Standard Test Method for Compressive Strength of Cylindrical Concrete Specimens
ASTM C40	Standard Test Method for Organic Impurities in Fine Aggregate for Concrete
ASTM C42	Standard Test Method for Obtaining and Testing Drilled Cores and Sawed Beams of Concrete
ASTM C88	Standard Test Method for Soundness of Aggregates by Use of Sodium Sulfate or Magnesium Sulfate
ASTM C94	Standard Specification for Ready-Mixed Concrete
ASTM C114	Standard Test Methods for Chemical Analysis of Hydraulic Cement
ASTM C117	Standard Test Method for Materials Finer than (75- $\mu$ m (No. 200) Sieve in Mineral Aggregates by Washing

ASTM C123	Standard Test Method for Lightweight Particles in Aggregate
ASTM C127	Standard Test Method for Relative Density (Specific Gravity) and Absorption of Coarse Aggregate
ASTM C128	Standard Test Method for Relative Density (Specific Gravity) and Absorption of Fine Aggregate
ASTM C131	Standard Test Method for Resistance to Degradation of Small-Size Coarse Aggregate by Abrasion and Impact in the Los Angeles Machine
ASTM C136	Standard Test Method for Sieve Analysis of Fine and Coarse Aggregates
ASTM C138	Standard Test Method for Unit Weight, Yield, and Air Contents (Gravimetric) of Concrete
ASTM C142	Standard Test Method for Clay Lumps and Friable Particles in Aggregates
ASTM C143	Standard Test Method for Slump of Hydraulic Cement Concrete
ASTM C150	Standard Specification for Portland Cement
ASTM C172	Standard Practice for Sampling Freshly Mixed Concrete
ASTM C231	Standard Test Method for Air Content of Freshly Mixed Concrete by the Pressure Method
ASTM C233	Standard Test Method for Air-Entraining Admixtures for Concrete
ASTM C260	Standard Specification for Air-Entraining Admixtures for Concrete
ASTM C311	Standard Test Methods for Sampling and Testing Fly Ash or Natural Pozzolans for Use as a Mineral Admixture in Portland Cement Concrete
ASTM C403	Standard Test Method for Time of Setting of Concrete Mixtures by Penetration Resistance

ASTM C494	Standard Specification for Chemical Admixtures for Concrete
ASTM C618	Standard Specification for Fly Ash and Raw or Calcined Natural Pozzolan for use as a Mineral Admixture in Portland Cement Concrete
ASTM C937	Standard Specification for Grout Fluidifier for Preplaced-Aggregate Concrete
ASTM C1064	Standard Test Method for Temperature of Freshly Mixed Portland Cement Concrete
ASTM C1097	Standard Specification for Hydrated Lime for Use in Asphalt Cement or Bituminous Paving Mixtures
ASTM C1116	Standard Specification for Fiber Reinforced Concrete
ASTM C1260	Standard Test Method for Potential Alkali Reactivity of Aggregates (Mortar-Bar Method)
ASTM C1567	Standard Test Method for Determining the Potential Alkali-Silica Reactivity of Combinations of Cementitious Materials and Aggregate (Accelerated Mortar-Bar Method)
ASTM C1602	Standard Specification for Mixing Water Used in the Production of Hydraulic Cement Concrete
ASTM C1603	Standard Test Method for Measurement of Solids in Water
ASTM D512	Standard Test Methods for Chloride Ion in Water
ASTM D516	Standard Test Method for Sulfate Ion in Water
ASTM D2419	Standard Test Method for Sand Equivalent Value of Soils and Fine Aggregate
ASTM D4318	Standard Test Methods for Liquid Limit, Plastic Limit, and Plasticity Index of Soils
ASTM D5821	Standard Test Method for Determining Percentage of Fractured Particles in Coarse Aggregate

ASTM D7508	Standard Specification for Polyolefin Chopped Strands for Use in Concrete
ICC AC32	Acceptance Criteria for Concrete with Synthetic Fibers
MAG Section 725	Portland Cement Concrete

1.4.4 Exceptions to this specification must be approved in writing by the Buyer prior to beginning the affected Work.

#### 1.5 Submittals

1.5.1 Concrete Supplier shall submit the following items for each batch plant (Plant) and mix to be supplied. All submittals must be current, and signed by person responsible for testing and/or certification. Expired and unsigned submittals may be rejected. Testing, sampling, and certification must be performed by a qualified, independent laboratory, agency, engineer, and/or oversight group:

- a. Plant Certification. A plant certification is required for each Plant proposed by Concrete Supplier to provide material. Certification to consist of ARPA Certification of Performance for Concrete Production Facilities, or NRMCA Plant Certification.
- b. Portland Cement Certification and Mill Test Report. Manufacturers certification is required from each source of Portland cement used in proposed mixes. Certification to include Certification of Test for Portland cement Type II/V Low Alkali meeting requirements of ASTM C150. Certification of Test to be dated within 1-year of submittal date, and must include source of Portland cement.
- c. Fly Ash Certification. Pozzolan Test Report is required from each source of fly ash used in proposed mixes. Test Report shall meet requirements of ASTM C618. Sampling and testing shall meet requirements of ASTM C311. Test Report to be dated within 1-year of submittal date, and must include source of fly ash.
- d. Hydrated Lime Certification. Certificate of Analysis is required from each source of hydrated lime used in proposed mixes. Certification shall meet requirements of ASTM C1097. Certification to be dated within 1-year of submittal date, and must include source of hydrated lime.

- e. Source of Water and Water Certification. Water used for the concrete mix and washing aggregate to meet requirements of ASTM C1602. State source of water for each proposed Plant as either City or "Other." City water does not require a submittal. Submit chemical analysis of "Other" water performed by an independent, qualified laboratory certifying suitability in accordance with ASTM C114 and ASTM C1603 for each proposed plant that uses "Other" water. Water analysis methods must meet ADEQ Accepted Laboratory Methods, and, as a minimum, should include the following:

- Alkalies (calculated)
- Chloride Content (EPA SM 4500-Cl C)
- Sulfate Content (EPA SM 4500-SO<sub>4</sub> D)
- Total Potassium (EPA 200.7)
- Total Sodium (EPA 200.7)
- Total Solids (EPA SM 2540 B)

Water certification must be dated within 1-year of submittal date. Report to include sample source, sample date, and sample time.

- f. Scale Certification. Documents of Certification are required for all scales used to weigh aggregates, cement, and admixtures. Certifications are required for every scale that may be used at each proposed plant. Date of certification must be within 1-year of submittal date.

- g. Fine Aggregate Certification. Fine aggregates to meet requirements of ASTM C33. Submit testing results of fine aggregates to be used within proposed mixes for each proposed plant. Where a single stockpile provides material for more than one plant, this stockpile requires only one certification with statement of which proposed plants the stockpile provides material. Date of certification must be within 1-year of submittal date. Testing, as a minimum, should include the following:

- Sieve Analysis of Fine and Coarse Aggregates (ASTM C136)
- Amount of Material Finer Than #200 Sieve (ASTM C117)
- Fineness Modulus (ASTM C136)
- Liquid Limit, Plastic Limit and Plasticity Index of Soils (ASTM D4318)
- Sand Equivalent Value for Soils and Fine Aggregate (ASTM D2419)
- Specific Gravity and Absorption of Coarse Aggregate (ASTM C128)
- Soundness of Aggregate by use of Sodium Sulfate (ASTM C88)

- Lightweight Particles in Aggregate (ASTM C123)
  - Clay Lumps and Friable Particles in Aggregate (ASTM C142)
  - Organic Impurities in Fine Aggregates for Concrete (ASTM C40)
- h. Coarse Aggregate Certification. Coarse aggregates to meet requirements of ASTM C33. Submit testing results of all single size and blended coarse aggregates used within proposed mixes for each proposed plant. Where a single stockpile provides material for more than one proposed plant, this stockpile requires only one certification with statement of which proposed plants the stockpile provides material. Date of certification must be within 1-year of submittal date. Testing, as a minimum, should include the following:
- Sieve Analysis of Fine and Coarse Aggregates (ASTM C136)
  - Amount of Material Finer Than #200 Sieve (ASTM C117)
  - Resistance to Degradation of Small Size Coarse Aggregate by Abrasion and Impact in the Los Angeles Machine (ASTM C131)
  - Clay Lumps and Friable Particles in Aggregate (ASTM C142)
  - Lightweight Pieces in Aggregate (ASTM C123)
  - Specific Gravity and Absorption of Coarse Aggregate (ASTM C127)
  - Soundness of Aggregate by use of Sodium Sulfate (ASTM C88)
  - Percentage of Crushed Particle in Mineral Aggregate (ASTM D5821)
  - Potential Alkali Silica Reaction (ASTM C1260/C1567)
- i. Admixture Certification. Submit manufacturer certifications for proposed admixtures to be used in proposed mixes. Admixtures requiring certification, as a minimum, may include the following:
- Normal Water Reducing Admixture (NWRA)
  - Mid-Range Water Reducing Admixture (MRWRA)
  - High-Range Water Reducing Admixtures (HRWRA)
  - Air Entraining Admixture (AEA)
  - Hydration Stabilizer Admixture “Retarder” (HSA)
  - Accelerator Admixture (Acc)
  - Micro and Macro-Fiber Admixture
  - Permeability Reducing Admixture for Concrete Subject to Hydrostatic Conditions (PRAH)
- j. Mix Designs. Provide sealed mix design for each proposed mix from each proposed plant. Mix designs that are used at more than one proposed plant require only a single submittal with comment on which proposed plants the mix design applies. Mix design to

include SRP stock code no., SRP SAP material item no., SRP product name, Concrete Supplier product code no., and Concrete Supplier product name. SRP stock code no. is currently used by Concrete Supplier and SRP in ordering material. The new SRP SAP material item no. is not presently used by Concrete Supplier and SRP, but will eventually be phased in. Mix design to include the applicable proportions, weights, and quantities of individual materials incorporated into the mix including the size of aggregates, type cement and fly ash, and the brand and designation of admixtures.

Mix design must be sealed within 1-year of the submittal date by an Arizona-registered professional engineer responsible for the mix. Preliminary submittals may use mix designs that are not sealed; however, final submittal of mix design must be sealed.

- k. Mix Design Performance and/or Trial Batch History. Provide performance history (including results of trial batches when available) for each proposed mix. Performance history includes items such as slump, compressive strength, time of set, delayed time of set with hydration stabilizer admixture, flow rate, thermal resistivity ( $\rho$ ), etc. If performance data is not available so state.

1.5.2 Concrete Supplier shall use SRP mix stock code numbers, SRP SAP material item nos., and SRP product names to refer to mixes, but may assign Concrete Supplier product code numbers and Concrete Supplier product names in addition to SRP mix stock code numbers and product names specified in Table 1. SRP SAP material item nos. are currently not used by Concrete Supplier and SRP, but will be eventually phased in.

1.5.3 Mixes and plants that have already been submitted to and approved by Buyer, and are current, do not require re-submittal. Re-submittal will be required at end of term of any agreements, or at any time determined by the Buyer.

1.5.4 In addition to specified materials and mixes, Concrete Supplier may submit alternative mix designs or deviations to the specifications for review and approval. Buyer may request additional test and/or certification documentation before approving alternatives.

## 1.6 Quality Assurance

1.6.1 Each batch plant from which Concrete Supplier intends to provide materials governed by this specification must have current NRMCA, ARPA, or equivalent certification.

1.6.2 Concrete Supplier shall provide access to batch plant to Buyer and Buyer's Representative for sampling/inspection of materials and equipment as required by the Buyer.

## 1.7 Storage and Handling

1.7.1 Materials shall be stored and handled in a manner that prevents deterioration, segregation, or intrusion of foreign matter.

1.7.2 Storage of aggregate on natural ground surface will be permitted if bottom six inches of pile is not used in batching.

## 2.0 PRODUCT

### 2.1 Cement

Cement: Portland Cement, Type II/V, low alkali, moderate heat of hydration, ASTM C150. Equivalent alkali content shall not exceed 0.60 percent, per Table 2, ASTM C150.

### 2.2 Aggregate

Coarse and fine aggregate: ASTM C33. Fine aggregate shall be sized as noted in Table 1 of ASTM C33. Coarse aggregate shall be sized as presented in Table 3 of ASTM C33.

### 2.3 Water

Water for washing aggregate and for mixing concrete shall be potable. If potable water is not used, chemical analysis of water shall be performed certifying suitability in accordance with ASTM C94, ASTM C1602, ASTM C1603, ASTM D512, and ASTM D516 by a qualified, independent testing laboratory. Testing will be at Concrete Supplier's expense.

### 2.4 Admixtures

2.4.1 Admixtures must be certified by manufacturer and shall be approved by the Buyer prior to use. Admixtures shall be added at the plant at the time of batching, unless otherwise noted. Admixtures shall contain not more than 0.1 percent water-soluble chloride ions by mass and shall be compatible with other admixtures. Do not use admixtures containing calcium chloride. Superplasticizer may be added at batch plant or at Jobsite.

#### 2.4.2 Air-Entraining Admixtures

a. Air-entraining admixtures: ASTM C260.



- b. Testing of air-entraining admixtures: ASTM C233.
- c. Air content (unless specified otherwise): ASTM 94, Section 6.1.4, 1, moderate exposure. Tolerance for air content as delivered  $\pm 1.5$  percent.

#### 2.4.3 Water-Reducing, Hydration Stabilizing (Retarding), and Accelerating Admixtures

- a. Water-reducing admixtures: ASTM C494, Type A.
- b. Water-reducing and retarding admixtures: ASTM C494, Type B & D.
- c. Accelerating Admixtures: ASTM C494, Type C.
- d. Water-reducing and accelerating admixture: ASTM C494, Type E.
- e. Water-reducing, high range admixtures (superplasticizers): ASTM C494, Type F.
- f. Water-reducing, high range, and retarding admixtures: ASTM C494, Type G.

#### 2.4.4 Fiber Admixtures

- a. Macro-fiber, micro-fiber, and macro/micro fiber blend admixtures: ASTM C1116.
- b. Steel Fiber-Reinforced Concrete: ASTM C1116, Type I.
- c. Glass Fiber-Reinforced Concrete: ASTM C1116, Type II.
- d. Synthetic Fiber-Reinforced Concrete: ASTM C1116, Type III, ASTM D7508, and ICC AC32.
- e. Natural Fiber-Reinforced Concrete: ASTM C1116, Type IV.
- f. Fiber may be ordered per ASTM C1116, Section 6, Option A where Buyer assumes responsibility for mixture proportioning and dictates type and dosage of fiber admixtures. Fiber reinforcement ordered by the Buyer will be synthetic macro-fiber, polypropylene copolymer, 2-inches long, unless otherwise requested. Synthetic micro-fiber, or blend of macro/micro fibers may be requested by the Buyer.

- g. Fiber may be ordered per ASTM C1116, Section 6, Option B where Buyer specifies required flexural performance and requires Concrete Supplier to assume full responsibility for fiber type and mixture proportioning. Fiber of Option B may be ASTM Type I, II, III, or IV.
- h. Fiber may be ordered per ASTM C1116, Section 6, Option C where Buyer specifies minimum allowable cement content and required flexural performance, and requires Concrete Supplier to assume responsibility for fiber type and mixture proportioning. Fiber of Option C may be ASTM Type I, II, III, or IV.
- i. Dosage of fiber admixture shall be in pounds per cubic yard of concrete.

#### 2.4.5 Grout Fluidifiers

Grout Fluidifiers: ASTM C937.

#### 2.4.6 Permeability Reducing Admixtures

Permeability reducing admixtures must be hydrophilic crystalline product for concrete subject to hydrostatic conditions (PRAH): ACI 212.3R.

#### 2.5 Fly Ash

2.5.1 Fly ash: ASTM C618, Class F.

2.5.2 Fly ash shall be used in all proposed mixes, unless noted otherwise in Table 1.

2.5.3 Fly ash shall be compatible with cement and shall not react deleteriously with alkalis in cement.

2.5.4 Maximum fly ash replacement ratio of cementitious material within mixes shall be as specified within MAG Section 725 "Portland Cement Concrete," unless otherwise specified by the Buyer. Concrete Supplier shall be responsible to determine replacement ratio for each pound of replaced cement to maintain specified compressive strength f'c and specified performance.

#### 2.6 Proportioning of Mix

2.6.1 Proportioning of Mix: ASTM C94.

- Option A: Buyer specifies requirement for compressive strength and Concrete Supplier to assume full responsibility for the selection of proportions for the concrete mixture.
- Option B: Buyer assumes responsibility for the proportioning of the mixture.
- Option C: Buyer specifies minimum allowable cement content and Concrete Supplier to assume responsibility for the selection of the proportions for the mix.

2.6.2 Minimum cementitious material content shall be as recommended in Table 725-1 of MAG Section 725.

Minimum Cementitious Material Content by Concrete Class (Table 725-1, Section 725 of MAG).		
Class of Concrete	Minimum Cementitious Materials Content (lbs./CY)	Minimum Compressive Strength at 28-Days (psi)
AA	600	4000
A	520	3000
B	470	2500
C	420	2000

2.6.3 Proportioning of ingredients shall produce a consistent, durable, and workable product that meets specified compressive strength, slump, properties per referenced standards in Section 1.4, requirements of Table 1, and other performance properties as required by the application. Mix shall be homogeneous, readily placeable, and sufficiently and uniformly workable.

2.6.4 Source, character or gradation of materials shall not be changed without notification of the Buyer. New mix design and possible performance verification must be submitted to the Buyer for approval when modifications to the mix are categorized in MAG Section 725 as "Modifications that require a new mix design submittal/approval and may require performance verification."

2.7 Measuring Materials

Measuring of materials: ASTM C94

2.8 Mixing

2.8.1 Mixing: ASTM C94.

- 2.8.2 Concrete to be central-mixed or truck-mixed with all ingredients added to the mix at the batch plant, unless otherwise noted.
- 2.8.3 Truck-mixed concrete shall be mixed per Section 12.5 of ASTM C94. Per the standard, the batch shall be mixed for 70 to 100 revolutions at mixing speed designated by the manufacturer to produce uniformity of concrete (typically 6 to 18 rpm).
- 2.8.4 High range water reducing admixtures (superplasticizers) may be added at batch plant or at Jobsite.
- 2.8.5 Fibers shall be added to the mix per manufacturer's recommendations and at a rate that insures proper distribution throughout the mix (no clumping).
- 2.8.6 Fly ash and cement shall be added in a manner and at a rate as to minimize presence of incomplete mixed nodules. Dry nodules over 1-inch diameter are not allowed. Concrete containing non-uniform material exceeding 1% of the total volume may be rejected by the Buyer with full cost the responsibility of the Concrete Supplier.
- 2.8.7 Retarding admixtures may be added to concrete to meet slump requirements and compensate for travel time to specific Jobsites. Volume of retarding agent added is responsibility of Concrete Supplier. Type and volume must be approved by the Buyer prior to batching.
- 2.9 Delivery and Batch Ticket
  - 2.9.1 Delivery: Section 12 of ASTM C94.
  - 2.9.2 Batch/Delivery Ticket: Section 14 of ASTM C94.
  - 2.9.3 Copy of delivery ticket is to be given to the Buyer at time of delivery. Batch out time of truck shall be machine-stamped on delivery ticket at Concrete Supplier's Plant. Concrete deliveries without machine-stamped batch out time on delivery ticket may be rejected by the Buyer.
  - 2.9.4 **Delivery ticket must include SRP Mix Stock Code No., SRP SAP Material Item No., SRP Product Name, Concrete Supplier Product Code No., and Concrete Supplier Product Name.** Material delivered with a delivery ticket that does not include these items may be rejected by the Buyer. SRP SAP material item no. is currently not used by Concrete Supplier and SRP, but will eventually be phased in.
  - 2.9.5 Concrete shall be delivered within 30 minutes of requested delivery time. Time lapse between successive deliveries shall not vary by more than

20 minutes from that requested. The Buyer may reject any batch not meeting these requirements.

## 2.10 Hot Weather Concreting

2.10.1 Hot weather concreting: ACI 305.1.

2.10.2 Concrete temperature shall not exceed 90°F during mixing, delivery, and discharging.

2.10.3 During conditions of high temperature, low relative humidity, or wind which might impair quality of concrete, setting time shall be delayed by using proper admixtures upon approval by the Buyer.

## 2.11 Cold Weather Concreting

2.11.1 Cold weather concreting: ACI 306.1.

2.11.2 Required concrete temperatures shall be as recommended in Table 3.2.1 of ACI 306.1. Concrete temperature during mixing, delivery, and discharge shall not be less than 55°F.

## 2.12 Direct and Indirect Costs

Direct and indirect costs incurred by Buyer due to failure to meet requirements of this specification shall be paid by Concrete Supplier and/or Contractor.

# 3.0 EXECUTION

## 3.1 Placement

3.1.1 Placement of concrete and cementitious materials: Section 26.5.2 of ACI 318, ACI 304R, and Section 12 of ASTM C94.

3.1.2 Unless a different allowable temperature range is pre-approved by the Buyer, temperature of concrete during production, delivery, and discharge shall never be outside the temperature range of 55°F (13°C) to 90°F (32°C). Concrete that is outside the temperature range of 55°F to 90°F, concrete that has become unworkable, or concrete that has attained its initial set, as determined by the Buyer, may be rejected at the Concrete Supplier's and/or Contractor's cost. Buyer may waive these limitations if slump, workability, and temperature is such that concrete can be placed as specified without the addition of water.

- 3.1.3 Unless designed using pre-approved set delay additives, concrete shall be discharged within 1-1/2 hours after initial mixing water has been added to cement and aggregate. This limitation may be waived by the Buyer if the concrete is of such slump, workability, and temperature after 1-1/2 hours that it can be placed, without addition of water to the mix. In hot weather, or under conditions contributing to rapid stiffening of the concrete, a time less than 1-1/2 hours may be specified by the Buyer.
- 3.1.4 Concrete Supplier shall be responsible to make corrections to bring mix to specified slump. Buyer's preference is that no water be added at the Jobsite. Addition of water at Jobsite requires Buyer's approval. When approved, additional water added at the Jobsite must be in accordance with Paragraph 12.7 of ASTM C94. Slump after such water addition must not exceed the maximum allowed by the Mix Design, and the water/cementitious material ratio must not exceed that specified by the Mix Design. All water additions are to be completed within 15 minutes from the start of first water addition. Added water must be mixed into the batch for a minimum of 30 additional revolutions at mixing speed (typically 6 to 18 rpm). Mix not meeting slump requirements may be rejected by the Buyer at the Concrete Supplier's cost.
- 3.1.5 Material shall be placed at a rate so as to provide adequate supply at the location of placement, at a rate at all times so material retains sufficient workability and can be self-consolidated or consolidated by external method, material remains homogeneous without segregation or loss of material, without interruptions between successive placements that may result in cold joints, and deposited near its final location to avoid segregation due to rehandling or flowing.
- 3.1.6 Cementitious material is prohibited to be in contact with aluminum, copper, or brass. No aluminum, copper, or brass conduits and tremies shall be used to pump or place cementitious material.
- 3.1.7 Masonry filler units that will be in contact with concrete shall be pre-wetted prior to placing concrete.
- 3.1.8 Free-fall height greater than 5-feet is prohibited, unless otherwise approved by the Buyer.
- 3.2 Testing, Strength Compliance, and Acceptance of Concrete
- 3.2.1 Testing
- a. Concrete samples will be taken directly from discharge of ready-mix transit truck. Sampling and testing will be in accordance with the following standards:

ASTM C138	Unit Weight & Yield
ASTM C143	Slump
ASTM C172	Sampling
ASTM C231	Air
ASTM C1064	Temperature

- b. Frequency for sampling concrete for strength compliance: Section 17 of ASTM C94 with the exception that Buyer standard requires one test per minimum 50 CY, or as otherwise specified by the Buyer.
- c. Frequency for sampling and testing for slump, air-content, and temperature compliance: Section 17 of ASTM C94, or as otherwise specified by the Buyer. Buyer requires, as a minimum, that this testing be performed when strength specimens are made. Testing of air content only required for batches that include an air-entraining admixture, unless otherwise directed by the Buyer.
- d. Standard set of cylindrical concrete samples for compressive strength testing to consist of 1 at 7-days, 2 at 28-days, and 1-hold cylinder, unless otherwise specified by the Buyer.
- e. Making and curing of concrete strength specimens: ASTM C31. Test specimens 4" diameter by 8" tall cylinders.
- f. Compressive strength testing of cylindrical concrete specimens: ASTM C39.

3.2.2 Testing specified in subsection 3.2.1 will be performed by the Buyer at no cost to Concrete Supplier or Contractor unless otherwise stated in the contract documents.

### 3.2.3 Compliance With Compressive Strength Provisions

Compressive strength will be considered satisfactory if test results meet the following requirements and Section 18 of ASTM C94, unless otherwise specified by the Buyer. Where requirement differs from ASTM C94, the requirement stated herein would have precedence. A set of strength tests consists of minimum two (2) 28-day test cylinders, 6" diameter by 12" tall, or 4" diameter by 8" tall, unless otherwise required by the Buyer:

- a. (This requirement has been added by the Buyer and is not included within ASTM C94). 7-day average compressive strength of one cylinder equals or exceeds 70-percent of the specified compressive strength  $f'_c$ . When more than one cylinder is available for testing, the average of the tested cylinders equals or exceeds 70-percent of the specified compressive strength and the compressive strength of a

single cylinder test is not less than 65-percent of the specified compressive strength.

- b. 28-day average compressive strength of any three consecutive sets of strength tests equals or exceeds specified compressive strength  $f'c$ .
- c. (This requirement has been added by the Buyer and deviates from ASTM C94). When three consecutive strength tests (minimum two cylinders per test) is not available for testing, the average compressive strength of any consecutive cylinder sets tested (one or two sets) equals or exceeds the specified compressive strength.
- d. For specified compressive strength of 5,000 psi or less, no individual set of strength test (average of minimum two cylinder tests) falls more than 500 psi below specified compressive strength  $f'c$  when at least three sets of strength tests are made. When less than three sets of strength tests are made, no individual cylinder strength falls below specified compressive strength  $f'c$ .
- e. For specified compressive strength greater than 5,000 psi, no set of strength test (average of minimum two cylinder tests) shall be less than 0.90  $f'c$ . When less than three sets of strength tests are made, no individual cylinder strength falls below specified compressive strength  $f'c$ .

#### 3.2.4 Failure to Meet Compliance Requirements

- a. Failure to meet requirements of subsection 3.2.3a indicates that potentially low-strength concrete has been delivered. Concrete Supplier and Contractor will be notified of potential problem for remedial action.
- b. Failure to meet requirements of subsections 3.2.3b or 3.2.3c or 3.2.3d or 3.2.3e shall be basis for investigation of low-strength concrete per subsection 3.2.5.

#### 3.2.5 Investigation of Low-Strength Concrete

- a. A set of three cores representing each strength test shall be taken.
- b. Cores shall be taken within 72 hours of testing for 28-day compressive strength, or as specified by the Buyer, in accordance with ASTM C42 and tested in accordance with ASTM C39.
- c. Concrete Supplier and/or Contractor shall be responsible for costs associated with investigation of low-strength concrete. However,



Concrete Supplier's and Contractor's cost will be reimbursed if requirements of subsection 3.2.6 have been satisfied.

### 3.2.6 Acceptance of Low-Strength Concrete

Concrete in an area represented by core tests will be considered acceptable if the average of three cores is minimum 85 percent of specified compressive strength  $f'_c$  and no single core is less than 75 percent of specified compressive strength  $f'_c$ .

When low-strength concrete is accepted by the Buyer on the basis of test results of less than 100% of the required minimum compressive strength, an adjustment in the concrete unit price may be made for the quantity of concrete represented by such strength tests in accordance with Table 725-2 of MAG Section 725.

Class AA and Class A		Class B and Class C	
Percent of Specified Minimum 28-day Compressive Strength Attained (Nearest 1%)	Percent of Concrete Unit Price Allowed	Percent of Specified Minimum 28-day Compressive Strength Attained (Nearest 1%)	Percent of Concrete Unit Price Allowed
100% or greater	100	100% or greater	100
98-99	90	95-99	95
96-97	85	90-94	90
95	80	85-89	85

### 3.2.7 Rejection of Low-Strength Concrete

Concrete failing to meet acceptance requirements of subsection 3.2.6 will be rejected. Concrete Supplier and/or Contractor shall be responsible for direct and indirect costs of removal and replacement of rejected concrete.

SRP SAP NUMBER	SRP STOCK CODE NUMBER	Description	Specified Min. Compressive Strength @ 28-Days fc (psi)	Coarse Aggregate Max. Size, ASTM C33 Table 2 (in)	Slump Range (in)	Air Content (+/-) 1.5% (%)	Min. Cementitious Material (#/CY)	Max. Water/Cementitious Material Ratio (by Wt.)	Remarks
5075320	00-00220	MAG C - 1"		1" (#57)	3 to 5	1.5	420	N/A	Can use as Canal Bottom
5079391	00-00222	ASTM C-476 Grout for Masonry (Coarse) - 3/8" w/Fly Ash	2,000	3/8" (#8)	8 to 11	1.5	PMD	0.55	Mix Per ASTM C476. 1-Part C+P, 0-0.10 Part Lime, Fine Agg 1.25-3 Times C+P, Coarse Agg 1-2 Times C+P (By Volume)
5075323	00-00230	MAG A - 1" or SRP Normal 3000 Mix	3,000	1" (#57)	3 to 5	1.5	520	0.58	Can Use as Canal Bottom
5079409	00-00231	MAG A - 1" Flowable		5 to 8					
5075324	00-00232	MAG A - 1/2" w/Air or SRP Slipform		2 to 4					
5079319	00-00233	MAG A - 1/2" or SRP Cable Trench		3 to 5					
5079345	00-00234	SRP 3000 Shotcrete - 3/8" w/5# Fiber	3,000	3/8" (#8)	2 to 4	5.5	PMD	0.50	75 to 85% Coarse Aggregate Passing 3/8" Sieve
5079319	00-00235	MAG A - 3/8" w/Air or SRP Ditchmix		3 to 5					
5079345	00-00236	SRP 3000 Shotcrete - 3/8" No Fiber		2 to 4					
5079319	00-00237	MAG A - 1/2" Flowable		5 to 8					
5079320	00-00238	MAG A - 1/2" Pumpable	4,000	1/2" (#7)	3 to 5	1.5	520	0.58	Use Superplasticizer
5079326	00-00239	MAG A - 1/2" Flowable & Pumpable		3 to 5					
5079326	00-00240	MAG AA - 1" or SRP Normal 4000 Mix		5 to 8					
5079321	00-00241	MAG AA - 1" w/Air		3 to 5					
5079321	00-00242	MAG AA - 1" Flowable	4,000	1" (#57)	3 to 5	1.5	600	0.50	Use Superplasticizer
5079368	00-00243	MAG AA - 1" Flowable w/Air		5 to 8					
5079341	00-00244	SRP 4000 1/2" Precast - No Fly Ash		3 to 5					
5079341	00-00245	SRP 4000 Pumpable - 1/2"		3 to 6					
5079341	00-00250	SRP 5000 - 1" Normal	5,000	1" (#57)	3 to 5	1.5	660	0.45	Use Superplasticizer
5079369	00-00251	SRP 5000 - 1" w/Air		5 to 8					
5079362	00-00252	SRP 5000 - 1" Flowable		3 to 5					
5079348	00-00253	SRP 5000 - 1" Flowable w/Air		5 to 8					
5079349	00-00254	SRP 5000 - 1" No Fly Ash	5,000	1/2" (#7)	3 to 5	1.5	PMD	0.40	Use Superplasticizer
5079350	00-00255	SRP 5000 - 1/2"		3 to 5					
5079351	00-00256	SRP 5000 - 1/2" No Fly Ash		3 to 5					
5079351	00-00257	SRP 3000@24-Hrs 5000@28-Days - 1"		3 to 5					

**Notes:**

- 1) Fiber Admixture may be added to any mix. Either Buyer dictates type and amount of fiber per ASTM C1116 Order Information Option A; or Buyer provides minimum flexural strength and Concrete Supplier determines mix proportions including fiber type and dosage. Fiber may consist of Macro, Micro, or Macro/Micro blend meeting requirements of ASTM C1116 "Fiber-Reinforced Concrete."
- 2) Hydration stabilizer admixtures (HSA, retarders) can be added to any mix. Buyer to either dictate dosage rate of HSA, or Buyer to dictate required extension in initial set of product (extending workability of product) and Concrete Supplier to determine admixture type and dosage.
- 3) Permeability reducing admixtures for concrete subject to hydrostatic conditions (PRAH) may be added to any mix. Buyer to either dictate PRAH type and dosage rate, or Buyer to dictate required specification and Concrete Supplier to determine type and dosage.

PMD - Per Mix Design

**SALT RIVER PROJECT**  
**WATER GROUP**  
**STANDARD SPECIFICATION**  
**FOR FIBER REINFORCED SHOTCRETE**  
**FOR CANAL BANK LINING**  
 (SRP 03364)

TABLE OF CONTENTS

SECTION	TITLE	PAGE
1.0	GENERAL	1
1.1	Work Specified	1
1.2	Work Performed by Purchaser	1
1.3	Standard Units	1
1.4	Reference Standards	1
1.5	Submittals	4
1.6	Quality Assurance	4
1.7	Storage and Handling	5
1.8	Emergency Releases	5
1.9	Access	5
1.10	Protection of Existing Structures	5
2.0	PRODUCT	5
2.1	Cement	5
2.2	Aggregate	5
2.3	Water	6
2.4	Admixtures	6
2.5	Fly Ash	6
2.6	Fiber Reinforcement	7
2.7	Proportioning of Mix	7
2.8	Measurement of Materials	7
2.9	Mixing	7
2.10	Delivery	8
2.11	Hot Weather Concreting	8
2.12	Cold Weather Concreting	8
2.13	Curing Compound	8

REVISED BY: K. L. CHHIBBER APPROVED BY: GUY LEARY

PREPARED BY: J. M. PATEL APPROVED BY: LARRY A. BOTTOLFSON

**SALT RIVER PROJECT**  
**WATER GROUP**  
**STANDARD SPECIFICATION**  
**FOR FIBER REINFORCED SHOTCRETE**  
**FOR CANAL BANK LINING**  
 (SRP 03364)

TABLE OF CONTENTS

SECTION	TITLE	PAGE
3.0	EXECUTION	9
3.1	Testing, Strength Compliance, and Acceptance of Concrete	9
3.2	Placement	11
3.3	Finishing	13
3.4	Joints	13
3.5	Curing	13
3.6	Equipment	14
3.7	Direct and Indirect Costs	15

REVISED BY: K. L. CHHIBBER

APPROVED BY: GUY LEARY

PREPARED BY: J. M. PATEL

APPROVED BY: LARRY A. BOTTOLFSON

**SALT RIVER PROJECT**  
**WATER GROUP**  
**STANDARD SPECIFICATION**  
**FOR FIBER REINFORCED SHOTCRETE**  
**FOR CANAL BANK LINING**  
**(SRP 03364)**

1.0 GENERAL

1.1 Work Specified

This specification covers the furnishing of all plant, labor, materials, tools and equipment necessary for mixing, delivering and placement of fiber reinforced shotcrete for canal bank lining.

1.2 Work Performed by Purchaser

1.2.1 Prior to canal bank lining work by the Contractor, the Purchaser will install concrete canal bottom lining and shape the canal banks. Generally, the Contractor will be able to begin work within two weeks after the beginning of canal dry-up. The Purchaser will make every effort not to impede the Contractor's work, and the Contractor shall in turn accommodate the Purchaser's work when required.

1.2.2 The Purchaser will spray the bank with water to maintain optimum soil moisture content during bank preparation and for a period ending 24 hours after Purchaser's notice to Contractor to shotcrete a specified section of canal bank. The Contractor shall be responsible to maintain optimum soil moisture content thereafter until completion of shotcreting the specified section of canal bank.

1.3 Standard Units

When both English and SI (metric) units are stated, the English units are the standard. The SI units are approximations listed for information only.

1.4 Reference Standards

1.4.1 Reference to standards or specifications shall be interpreted to mean the latest revision unless noted otherwise.

1.4.2 The following abbreviations appear in this Specification:

ACI	American Concrete Institute
ARPA	Arizona Rock Products Association
ASTM	American Society for Testing and Materials
NRMCA	National Ready-Mixed Concrete Association
SRP	Salt River Project (Purchaser)

1.4.3 The following standards shall be made a part of this Specification:

ACI 305R	Hot Weather Concreting
ACI 306.1	Standard Specification for Cold Weather Concreting
ACI 318/318M	Building Code Requirements for Reinforced Concrete
ACI 506R	Guide to Shotcrete
ACI 506.2	Specification for Materials, Proportioning, and Application of Shotcrete
ASTM C31	Standard Practice for Making and Curing Concrete Test Specimens in the Field
ASTM C33	Standard Specification for Concrete Aggregates
ASTM C39	Standard Test Method for Compressive Strength of Cylindrical Concrete Specimens
ASTM C42	Standard Test Method for Obtaining and Testing Drilled Cores and Sawed Beams of Concrete
ASTM C94	Standard Specification for Ready-Mixed Concrete
ASTM C138	Standard Test Method for Unit Weight, Yield, and Air Contents (Gravimetric) of Concrete
ASTM C143	Standard Test Method for Slump of Hydraulic Cement Concrete
ASTM C150	Standard Specification for Portland Cement

ASTM C172	Standard Practice for Sampling Freshly Mixed Concrete
ASTM C231	Standard Test Method for Air Content of Freshly Mixed Concrete by the Pressure Method
ASTM C233	Standard Test Method for Air-Entraining Admixtures for Concrete
ASTM C260	Standard Specification for Air-Entraining Admixtures for Concrete
ASTM C309	Standard Specification for Liquid Membrane-Forming Compounds for Curing Concrete
ASTM C311	Standard Test Methods for Sampling and Testing Fly Ash or Natural Pozzolans for Use as a Mineral Admixture in Portland Cement Concrete
ASTM C494	Standard Specification for Chemical Admixtures for Concrete
ASTM C618	Standard Specification for Fly Ash and Raw or Calcined Natural Pozzolan for Use as a Mineral Admixture in Portland Cement Concrete
ASTM C1064	Standard Test Method for Temperature of Freshly Mixed Portland Cement Concrete
ASTM C1116	Standard Specification for Fiber-Reinforced Concrete and Shotcrete
ASTM D512	Standard Test Methods for Chloride Ion in Water
ASTM D516	Standard Test Method for Sulfate Ion in Water
SRP 03300	SRP Standard Specification for Concrete

1.4.4 Exceptions to this specification must be approved in writing by the Engineer prior to beginning the affected work.

## 1.5 Submittals

1.5.1 Contractor/concrete supplier shall submit the following items for each mix to be supplied:

- a. Plant certification
- b. Mix design
- c. Mix design performance/trial batch data
- d. Source and gradation of fine and coarse aggregate
- e. Cement certification and mill test report
- f. Fly ash certification
- g. Fly ash replacement ratio
- h. Admixture brand and certification
- i. Source of water and certification

1.5.2 Mix designs shall be submitted to the Engineer for approval a minimum of one week prior to the beginning of work.

1.5.3 In lieu of the submittals required per Sections 1.5.1 and 1.5.2, Contractor/concrete supplier may use pre-approved mix design for shotcrete, SRP Stock Code No. 0000234 per Specification SRP 03300, with fiber added.

## 1.6 Quality Assurance

1.6.1 Each batch plant from which concrete supplier intends to provide concrete must have current NRMCA, ARPA or equivalent laboratory certification.

1.6.2 Concrete supplier shall provide documentation that an Arizona-registered professional engineer has reviewed mix designs and other submittals prior to submitting to the Purchaser for approval.

1.6.3 Concrete supplier shall provide access to batch plant for sampling/inspection of materials and equipment.



## 1.7 Storage and Handling

1.7.1 Materials shall be stored and handled in a manner that prevents deterioration, segregation, or intrusion of foreign matter.

1.7.2 Storage of aggregate on natural ground surface will be permitted if bottom six inches of pile is not used in batching.

## 1.8 Emergency Releases

1.8.1 SRP will provide a minimum of 2 hours advance warning of emergency water releases into the canal. The Contractor shall store materials and equipment in a safe location, and SRP will not be responsible for loss of materials or equipment resulting from emergency releases. The loss of completed construction or immovable materials will be paid by the Purchaser at the unit cost bid.

1.8.2 The Contractor will not be paid for any portion of the work not completed before the scheduled end of canal dry-up and which work is damaged by water releases into the canal.

## 1.9 Access

Suitable roadways for construction traffic exist along both sides of the canal in most locations. The Bidder should review all sites to determine actual conditions. Access to the canal roadways exists at major road crossings of the canal.

## 1.10 Protection of Existing Structures

The Contractor shall take the necessary precautions to protect existing bridges and canal structures. Damage to any existing structures shall be repaired to the satisfaction of the Engineer at the expense of the Contractor.

## 2.0 PRODUCT

### 2.1 Cement

Cement shall be Portland cement, Type II, low alkali, moderate heat of hydration, conforming to ASTM C150. Equivalent alkali content shall not exceed 0.6 percent, per Table 2, ASTM C150.

### 2.2 Aggregate

Coarse and fine aggregate shall conform to ASTM C33.

## 2.3 Water

Water for washing aggregate and for mixing concrete shall be potable or shall meet requirements of ASTM C94. If potable water is not used, concrete supplier shall have independent testing laboratory perform chemical analysis of water certifying suitability in accordance with ASTM D512 and ASTM D516.

## 2.4 Admixtures

2.4.1 Admixtures for the mix design shall not be substituted without prior written approval of the Engineer.

### 2.4.2 Air-Entraining Admixtures

- a. Air-entraining admixtures shall conform to ASTM C260.
- b. Air-entraining admixtures shall be tested in accordance with ASTM C233.
- c. Air content, unless specified otherwise, shall conform to ACI 318, Table 4.2.1, moderate exposure. Tolerance for air content as delivered shall be  $\pm 1.5$  percent.

### 2.4.3 Water-Reducing, Retarding, and Accelerating Admixtures

- a. Water-reducing, retarding, and accelerating admixtures shall conform to ASTM C494.
- b. Chloride admixtures shall not be used.

### 2.4.4 Superplasticizers

Superplasticizers shall conform to ASTM C494, Type F or G.

## 2.5 Fly Ash

2.5.1 Fly ash shall be used in all mix designs.

2.5.2 Fly ash shall conform to ASTM C618, Class F.

2.5.3 Fly ash shall be compatible with cement and shall not react deleteriously with alkalis in cement. Concrete supplier shall have fly ash sampled and tested in accordance with ASTM C311.

2.5.4 Maximum 25 percent of weight of cement required for mix design may be replaced with fly ash. Concrete supplier shall be responsible to determine

replacement ratio for each pound of replaced cement to maintain specified compressive strength  $f'_c$ .

## 2.6 Fiber Reinforcement

2.6.1 Fiber reinforcement shall be Euclid Chemical Company TUF-STRAND SF Synthetic Macro-Fiber, polypropylene/polyethylene copolymer, 2 inch long; or SRP approved equivalent. Fibers shall comply with the material specifications and performance requirements of ASTM C1116.

2.6.2 Total amount of fibers in the mix shall be 5 pounds per cubic yard of concrete.

2.6.3 Fiber will be the only reinforcing used in the shotcrete for canal bank lining.

## 2.7 Proportioning of Mix

2.7.1 Source, character or gradation of materials shall not be changed without prior written approval of the Engineer.

2.7.2 Mix shall be homogeneous, readily placeable and uniformly workable. Proportioning of ingredients shall produce consistency, durability, workability, specified compressive strength  $f'_c$ , and other properties as required per reference standards in Section 1.4.

2.7.3 Mix shall develop compressive strength  $f'_c$  of 3000 psi at 28 days. Mix shall have a maximum water/cementitious material ratio of 0.47 by weight.

## 2.8 Measurement of Materials

Material shall be measured in accordance with ASTM C94.

## 2.9 Mixing

2.9.1 Mixing shall follow the procedures in accordance with ASTM C94.

2.9.2 All ingredients shall be added to the mix at the batch plant. Fibers shall be added to the mix per manufacturer's recommendations and at a rate that avoids clumping of fibers in the mix. Minimum mixing time after introduction of fibers shall be five minutes at high rpm.

2.9.3 Design slump at the discharge end of the nozzle shall be 3" ( $\pm 1$ ").

## 2.10 Delivery

2.10.1 Ready-mix concrete shall be produced and delivered in accordance with ASTM C94. Concrete that is outside the temperature range of 55° F to 90° F, or has attained its initial set upon arrival at jobsite, as determined by the Engineer, will be rejected at concrete supplier's cost. Engineer may waive these limitations if slump is such that concrete can be placed without addition of water.

Concrete shall be discharged within 1-1/2 hours after initial mixing water has been added to cement and aggregate.

2.10.2 Concrete supplier shall be responsible to make corrections to bring mix to specified slump. Only one addition of water to bring mix to specified slump shall be allowed. Mix not meeting slump requirements will be rejected.

2.10.3 Batch out time of truck shall be machine-stamped on delivery ticket at concrete supplier's plant. A copy of delivery ticket having machine-stamped batch out time shall be given to the Engineer at time of delivery. Concrete deliveries without machine-stamped batch out time on delivery ticket will be rejected.

2.10.4 Concrete shall be delivered within 30 minutes of requested delivery time. Time lapse between successive deliveries shall not vary by more than 20 minutes from that requested. The Engineer may reject any batch not meeting these requirements.

## 2.11 Hot Weather Concreting

2.11.1 Hot weather concreting shall be in accordance with ACI 305R. The concrete temperature during discharge shall not exceed 90° F.

2.11.2 During conditions of high temperature, low relative humidity or wind which might impair quality of concrete, setting time shall be delayed by using proper admixtures.

## 2.12 Cold Weather Concreting

Cold weather concreting shall be in accordance with ACI 306.1. Concrete temperature during discharge shall not be less than 55° F.

## 2.13 Curing Compound

The curing compound shall be a white pigmented compound in accordance with the requirements of ASTM C309 for a Type 2, Class A compound.

### 3.0 EXECUTION

#### 3.1 Testing, Strength Compliance, and Acceptance of Concrete

##### 3.1.1 Testing

- a. Frequency for sampling concrete for strength compliance will be in accordance with ACI 318 or as specified by the Engineer.
- b. Concrete samples shall be taken directly from transit mix truck, unless specified otherwise. Sampling and testing will be in accordance with the following standards:

ASTM C138	Unit Weight & Yield
ASTM C143	Slump (sample from nozzle)
ASTM C172	Sampling
ASTM C231	Air
ASTM C1064	Temperature

- c. Concrete strength specimens shall be made in accordance with ASTM C31. Test specimens shall be 4 inch diameter by 8 inch long cylinders.

Test cylinders shall be tested in accordance with ASTM C39.

- e. The Engineer will install forms for producing 24-inch square test panels. The test panels shall be filled during the shotcrete placement and removed immediately thereafter by the Contractor. The panel voids shall be refilled immediately following removal of the forms.

3.1.2 Testing specified in Section 3.1.1 will be performed by the Engineer at no cost to Contractor.

##### 3.1.3 Compliance with Compressive Strength Provisions

Compressive strength will be considered satisfactory if test results meet following requirements:

- a. 7-day average compressive strength, per strength test (average of two cylinders) equals or exceeds 70 percent specified compressive strength f'c.
- b. 28-day average compressive strength of all sets of three consecutive strength tests equals or exceeds specified compressive strength f'c.

- c. No individual strength test (average of two cylinders) falls more than 500 psi below specified compressive strength  $f'_c$  when at least three strength tests are made.
- d. When less than three strength tests are made, no individual cylinder strength falls below specified compressive strength  $f'_c$ .

#### 3.1.4 Failure to Meet Compliance Requirements

- a. Failure to meet requirements of Section 3.1.3a indicates that potentially low-strength concrete has been delivered. Contractor will be notified of potential problem for remedial action.
- b. Failure to meet requirements of Section 3.1.3b or Section 3.1.3c shall be the basis for investigation of low-strength concrete per Subsection 3.1.5.
- c. Failure to meet requirements of Section 3.1.3d will be the basis for investigation of low-strength concrete per Section 3.1.5.

#### 3.1.5 Investigation of Low-Strength Concrete

- a. A set of three cores or sawcut prisms representing each strength test shall be taken.
- b. Cores or prisms shall be taken within 72 hours of testing for 28-day compressive strength or as specified by the Engineer, in accordance with ASTM C42 and tested in accordance with ASTM C39.
- c. Contractor shall be responsible for costs associated with investigation of low-strength concrete. However, Contractor's cost will be reimbursed if requirements of Section 3.1.6 have been satisfied.

#### 3.1.6 Acceptance of Low-Strength Concrete

Concrete in an area represented by core or prism tests will be considered acceptable if the average of three tests is minimum 85 percent specified compressive strength  $f'_c$  and no single test is less than 75 percent specified compressive strength  $f'_c$ .

### 3.1.7 Rejection of Low-Strength Concrete

Concrete failing to meet acceptance requirements of Section 3.1.6 will be rejected. Contractor shall be responsible for direct and indirect costs of removal and replacement of rejected concrete.

## 3.2 Placement

3.2.1 Placement of canal bank shotcrete shall be in accordance with ACI 506R and ACI 506.2.

3.2.2 The canal bank shotcrete lining shall be placed after completion of the canal bottom concrete placement.

3.2.3 The shotcrete shall not be placed until the Engineer has approved the canal bank preparation.

3.2.4 All absorptive surfaces against which the shotcrete is to be placed shall be uniformly moistened and maintained within 2% of the optimum moisture content at all times prior to placement of the bank lining. Caution shall be taken to prevent erosion or over-saturation of the subgrade surface during the moistening process. The water shall be applied through the use of a nozzle or spray bar to provide an even spray distribution and to prevent erosion of the subgrade surface. The equipment necessary to obtain the required moisture content shall be approved by the Engineer and kept available on the jobsite throughout the construction. Failure to comply with these requirements shall result in a temporary shutdown of the shotcrete placement until the requirements are met to the satisfaction of the Engineer.

3.2.5 At the time of application, there shall be no free water on the surface upon which the shotcrete is to be placed.

3.2.6 The bank subgrade, top cut-off key, and the edge of the canal bottom concrete shall be free of any loose or spoil material prior to installation of the shotcrete.

3.2.7 Any disturbance to the prepared bank subgrade surface shall be repaired to the satisfaction of the Engineer prior to placing the shotcrete.

3.2.8 The Contractor shall notify the Engineer of the shotcrete placement schedule prior to any shotcrete operations.

3.2.9 The canal bottom concrete at the edge of the bank shall be thoroughly cleaned of all foreign matter and shall be free of surface water. The area to be

cleaned shall be the entire surface where shotcrete will join the canal bottom lining.

3.2.10 The Contractor shall be responsible for providing all equipment necessary to place the shotcrete in accordance with this specification. Special equipment may be required where the vertical lining height is 7 feet or greater.

3.2.11 The shotcrete for the top of the lining section and the cut-off key shall be installed from the top of the canal bank.

3.2.12 The canal bank shotcrete lining shall be placed with a minimum thickness of 3 inches, unless otherwise shown on the drawings or directed in writing by the Engineer. Tolerance shall be  $+1/2"$ ,  $-0"$ .

3.2.13 The grade at top of shotcrete canal bank lining shall be finished at design grade ( $\pm 0.1$  foot).

3.2.14 Shotcrete application shall begin at the bottom of the canal bank and continue to the top. The nozzle shall be held at a distance of 4 to 6 feet from and directed perpendicular to the canal bank surface. The nozzle shall be rotated steadily in a series of small oval or circular patterns. Angle shooting will only be allowed when no other suitable alternative exists.

3.2.15 Rebound material left on the soil bank for more than 30 minutes shall be removed and discarded prior to continuing shotcrete application.

3.2.16 When work is to be suspended at the end of the day or otherwise for a period exceeding 30 minutes, the end of the shotcrete placement shall be sloped to a thin edge. Prior to resuming work, the surface of the shotcrete upon or against which fresh shotcrete is to be placed shall be prepared for continuation of shotcrete placement. The bonding area shall be thoroughly cleaned, moistened, roughened, and when deemed necessary by the Engineer, a suitable bonding agent shall be applied to ensure thorough bonding of the fresh shotcrete to the previously placed shotcrete.

3.2.17 Longitudinal cold joints in the concrete shall not be permitted, and the maximum length of each longitudinal placement shall be determined by the Engineer, but in no case shall exceed 50 feet in length. Shotcrete shall be placed in a staggered pattern.

3.2.18 Precautions shall be taken, as deemed necessary by the Engineer, to avoid or minimize accumulations of rebound. Any excess rebound shall be removed at the time of placement to prevent excessive buildup on the canal bottom.



### 3.3 Finishing

3.3.1 The finished surface shall be smooth, uniform and even and shall be finished with a wet, fine-bristled broom immediately following the application of the shotcrete. The broom finish shall be applied by directing the broom in the upward direction only, over the surface of the shotcrete lining.

3.3.2 The finished surface shall be free of any rock pockets or surface voids. Fresh overspray onto freshly finished shotcrete shall be refinished as specified above.

3.3.3 Water containers for immersing the finishing broom shall be provided to facilitate obtaining the specified finish.

3.3.4 Extension handles for the finishing tools may be required as deemed necessary by the Engineer, depending on the vertical height of the shotcrete lining.

### 3.4 Joints

3.4.1 Tooled vertical control joints shall be installed immediately following broom finishing.

3.4.2 Control joints shall extend full height of the sloped shotcrete lining, including the cut-off key at the top of the lining.

3.4.3 Tooled control joints shall be 3/4-inch deep.

3.4.4 Maximum spacing between control joints shall be 10 feet unless otherwise shown on the drawings or directed by the Engineer..

### 3.5 Curing

3.5.1 As the shotcrete placement progresses, the shotcrete lining placed shall be cured by membrane curing. Membrane curing shall consist of the application of a white-pigmented curing compound as specified in Section 2.13.

3.5.2 The curing compound shall be applied immediately after all free water has left the shotcrete surface.

3.5.3 The curing compound shall be sprayed in a single application to provide a continuous, uniform, white membrane over the entire shotcrete surface and extending a minimum of one foot onto the canal bottom concrete.

3.5.4 The application rate shall be at the minimum rate of one gallon per 100 square feet, and may be increased as directed by the Engineer to obtain the required continuous membrane.

3.5.5 The curing compound shall be thoroughly mixed to a uniform consistency by stirring or agitation with an automatic mixer prior to and throughout the application process, as approved by the Engineer.

3.5.6 The canal safety steps drawings shall not be sprayed with curing compound in areas noted on the drawings to be painted by the Purchaser. Contractor shall cover such areas with plastic sheet for curing.

3.5.7 The concrete shall be protected from exposure to carbon monoxide or carbon dioxide fumes from heaters or engines.

### 3.6 Equipment

3.6.1 All equipment and the method of operation of the equipment shall be in accordance with accepted practice for this type of work, and shall be subject to the approval of the Engineer.

3.6.2 The shotcrete equipment shall include a boom capable of extending out over the canal bank, sufficient in strength to support the weight of the discharge and air hoses, and long enough to prevent the hoses from dragging on the canal bank.

3.6.3 Aluminum pipe shall not be used for pumping.

3.6.4 The production capacity of all equipment shall be adequate for proper performance of the work and to meet the Purchaser's schedule.

3.6.5 Placement may be temporarily halted, at the discretion of the Engineer, due to any equipment failure or slowdown.

3.6.6 Air pressure fed to the nozzle shall be maintained at a uniform pressure of not less than 80 pounds per square inch.

3.6.7 A 300 gallon minimum capacity water tank for each shotcrete rig plus an additional backup tank of the same capacity shall be on the job site during the shotcrete lining placement, unless otherwise approved by the Engineer.

3.6.8 The backup tank shall be available to prevent temporary shutdowns caused while refilling the water tanks. The tanks shall be equipped with a pump and nozzle or spray bar capable of discharging water with adequate pressure to maintain the required bank subgrade moisture, as specified in Section 3.2.3, prior to installing the shotcrete lining.

3.6.9 For access into and out of the canal, provide one ladder on each bank at each area where work is being performed. Climbing on the prepared canal bank subgrade will not be permitted.

### 3.7 Direct and Indirect Costs

Direct and indirect costs incurred by Purchaser due to failure to meet requirements of this specification shall be paid by Contractor.

SALT RIVER PROJECT  
 GENERATION ENGINEERING  
STANDARD SPECIFICATION  
FOR  
CONCRETE FORMWORK AND PLACEMENT  
 (GE 03305)

TABLE OF CONTENTS

SECTION	TITLE	PAGE
1 0	GENERAL	1
1.1	Work Specified	1
1.2	Reference Standards	1
1.3	Submittals	2
2.0	PRODUCT	3
2 1	Materials	3
2 2	Curing Compound	3
2.3	Form Lumber	3
2.4	Metal Forms	3
2 5	Other Accessories	4
3 0	EXECUTION	4
3 1	Forming	4
3 2	Reinforcing Steel Placement	5
3 3	Waterstop Installation	6
3 4	Concrete Placement	6
3 5	Consolidation	7
3 6	Finishing	8
3 7	Curing	9
3 8	Form Removal	9
3 9	Tolerances	10
3 10	Quality Control	10

PREPARED BY K. L. CHHIBBER      APPROVED BY LARRY A. BOTTOLFFSON

REVISED BY K. L. CHHIBBER  APPROVED BY LARRY A. BOTTOLFFSON 

STANDARD SPECIFICATION  
FOR  
CONCRETE FORMWORK AND PLACEMENT  
(GE 03305)

1 0 GENERAL

1 1 . Work Specified

This Specification covers the furnishing of labor, equipment and materials needed to form, place, consolidate, finish and cure cast-in-place concrete

1 2 Reference Standards

1 2.1 Reference to standards or specifications shall be interpreted to mean the latest revision unless noted otherwise.

1.2.2 The following abbreviations appear in this Specification

ACI	American Concrete Institute
ASTM	American Society for Testing and Materials
CRSI	Concrete Reinforcing Steel Institute
SRP	Salt River Project

1 2 3 The following Standards shall be made a part of this Specification.

ACI 117	Standard Specification for Tolerances for Concrete Construction and Materials
ACI 302	Guide for Concrete Floor and Slab Construction
ACI 304R	Guide for Measuring, Mixing, Transporting, and Placing Concrete
ACI 304	Placing Concrete by Pumping Methods
ACI 305R	Hot Weather Concreting
ACI 306 1	Standard Specification for Cold Weather Concreting

ACI 308	Standard Practice for Curing Concrete
ACI 309R	Guide for Consolidation of Concrete
ACI 318/318M	Building Code Requirements for Reinforced Concrete
ACI 347R	Guide to Formwork for Concrete
ASTM C309	Standard Specification for Liquid Membrane-Forming Compounds for Curing Concrete
ASTM C920	Standard Specification for Elastomeric Joint Sealants
ASTM D1752	Standard Specification for Preformed Sponge Rubber and Cork Expansion Joint Fillers for Concrete Paving and Structural Construction
CRSI	CRSI Recommended Practice for Placing Reinforcing Bars
SRP 03210	Salt River Project Standard Specification for Reinforcing Steel
SRP 03300	Salt River Project Standard Specification for Concrete
GE 07920	Generation Engineering Standard Specification for Caulking and Sealants

1.2.4 Exceptions to this specification must be approved in writing by the Engineer prior to beginning the affected work.

### 1.3 Submittals

Fabrication and placement drawings for reinforcing steel and embedded items, mix designs, and Manufacturer's Material Safety Data Sheets (MSDS) for chemicals shall be submitted to the Engineer for approval at least five working days prior to placement of concrete. Work shall not proceed until submittals have been approved by the Engineer.

## 2.0 PRODUCT

### 2.1 Materials

2.1.1 Concrete shall conform to SRP 03300.

2.1.2 Reinforcing steel shall conform to SRP 03210

2.1.3 Waterstop shall be dumbbell shape extruded elastomeric polyvinyl chloride of type, width and thickness specified on Drawings.

2.1.4 Expansion joint filler material shall be preformed neoprene sponge rubber conforming to ASTM D1752, Type I

2.1.5 Elastomeric sealants for expansion and control joints shall conform to GE 07920 Polyethylene foam backer rod shall be used for back-up of cold-applied elastomeric sealants.

2.1.6 Sealants in fuel or chemically active water containments shall be compatible with properties of stored material

### 2.2 Curing Compound

Curing compound shall conform to ASTM C309 Type 1-D, Class A clear resin compound shall be used for interior applications Type 1-D, Class A clear resin compound with fugitive dye or Type 2, Class A white-pigmented wax emulsion compound shall be used for exterior applications

### 2.3 Form Lumber

Form lumber in contact with exposed concrete surfaces shall be new and shall conform to the following:

- a. Structural Plywood, Class I or II. High-density overlay shall be used when highly smooth, grain-free concrete surface is required
- b. Dimension lumber, Douglas Fir or Larch, Number 2 grade, seasoned and surfaced all sides

### 2.4 Metal Forms

A commercial metal forming system or combination metal and plywood forming system may be used provided it is straight, clean and assembled to manufacturer's instructions

## 2.5 Other Accessories

2.5.1 Form accessories such as, but not limited to, styrofoam form liners or fiberglass may be used

2.5.2 Form accessories or other embedded items which are to be partially or entirely embedded in concrete shall be of a commercially manufactured type.

2.5.3 Aluminum pipe which is to be embedded in concrete shall be completely taped with Polyken two-inch wide pipe wrap, spiral wrapped with 50% overlap

2.5.4 Reinforcing bar supports shall conform to CRSI Class 3 (bright wire) for use in contact with formed surfaces that will not be exposed, and CRSI Class 1 (plastic tipped or coated) for use in contact with formed surfaces that will be exposed

2.5.5 Concrete block or plastic reinforcing bar supports may also be used

## 3.0 EXECUTION

### 3.1 Forming

3.1.1 Contractor shall be responsible for design and construction of forms, in accordance with ACI 347R. Forms shall have adequate strength to support weight of fresh concrete and added loads imposed by workers, wind and construction equipment.

3.1.2 Forms shall be designed, constructed, braced, and maintained so that finished concrete will be true to line and elevation, and will conform to dimensions and contours specified in Contract Documents. Forms shall be sufficiently tight to prevent leakage of mortar paste

3.1.3 Reusable forms shall be maintained and kept in good condition as to accuracy of shape, strength, rigidity, watertightness, and smoothness of surface. Forms unsatisfactory to the Engineer shall not be used

3.1.4 Three-quarter inch chamfer shall be provided in forms at exposed corners and edges of concrete. Horizontal edges of curved forms may be radiused with an edging tool

3.1.5 Forms shall be treated with form-release agent which will not adhere to or discolor concrete. Form-release agent shall be cleaned from rebar and other embedded items prior to concrete placement



3.1.6 Shear keys in construction joints shall be formed prior to concrete placement.

### 3.2 Reinforcing Steel Placement

3.2.1 Reinforcing steel shall be positioned on supports, spacers or hangers and secured in place with wire ties or clips. Welding of reinforcing steel and embedded items will not be permitted.

3.2.2 Reinforcing steel shown on Drawings is the minimum required. Additional bars may be added for working supports, at Contractor's expense, provided these do not interfere with concrete placement or violate concrete cover requirements.

3.2.3 Solid grout or concrete blocks or non-eroding chairs or bolsters shall be used to position bottom mat of slab reinforcing steel.

3.2.4 The following minimum concrete cover shall be provided for reinforcing steel, unless noted otherwise in Contract Documents:

- |    |  |              |
|----|--|--------------|
| a. | Concrete cast against and permanently exposed to earth.    | 3 inches     |
| b. | Concrete exposed to earth or weather                       |              |
|    | #6 through #18 bars  | 2 inches     |
|    | #5 bar, W31 or D31 wire, and smaller                       | 1-1/2 inches |
| c. | Concrete not exposed to weather nor in contact with earth: |              |
|    | Slabs, Walls, Joists                                       |              |
|    | #11 bar and smaller  | 3/4 inch     |
|    | #14 and #18 bars   | 1-1/2 inches |
|    | Beams, Columns:  |              |
|    | Primary Reinforcement, Ties,                               |              |
|    | Stirrups, Spirals  | 1-1/2 inches |

3.2.5 Contact splices of reinforcing steel are preferred. Noncontact splices shall be spaced no farther apart transversely than 1/5 required lap splice length nor six inches clear distance.

### 3.3 Waterstop Installation

Waterstop shall be accurately located and properly braced to prevent movement during placement of concrete. Waterstop shall be clean and free of dirt, grease or concrete splatter. Splices shall be kept minimum, but when unavoidable, splices shall be made using teflon coated splicing iron to assure watertight joints. Prefabricated intersections shall be used where possible.

### 3.4 Concrete Placement

3.4.1 Contractor shall notify the Engineer at least 24 hours in advance of each proposed concrete placement. Installation of anchor bolts, reinforcing steel, embedded items, and forms shall be approved by the Engineer prior to concrete placement.

3.4.2 Unless specifically waived by the Engineer, concrete placement shall be done in the presence of the Engineer and shall not commence until the work has been authorized to proceed.

3.4.3 Concrete slabs on grade shall be placed on undisturbed soil or compacted subgrade. Frozen subgrade or subgrade that contains frozen materials will not be acceptable.

3.4.4 Forms and construction joint surfaces shall be clean and free of foreign materials. Sandblasting, water-blasting, or other methods specified in ACI 304R shall be used to achieve a clean interface at construction joints.

3.4.5 Subgrade shall be dampened and excess water removed prior to placement of concrete on grade. Wooden forms that will be in contact with concrete shall be thoroughly moistened unless wood has been properly treated with form release agent. When ambient temperature exceeds 90°F, fog nozzles shall be used to cool reinforcing steel and forms prior to concrete placement. When temperature of reinforcing steel is greater than 120°F, steel forms and reinforcing steel shall be sprayed with water just prior to placing concrete. During cold weather (mean daily temperature below 40°F), ice, snow and frost shall be removed from reinforcing steel and placement areas and temperature of all surfaces which will be in contact with fresh concrete shall be raised to minimum 40°F. Minimum concrete temperature of 50°F shall be maintained during and after placement.

3.4.6 Concrete from mixer shall be conveyed and deposited in place by methods which will prevent segregation or loss of materials. Where concrete trucks cannot access jobsite, concrete shall be pumped or conveyed, or energy dissipating chutes (elephant trunks) shall be used.

3.4.7 Equipment for chuting and pumping concrete shall be of a size and design that can provide a continuous flow of concrete at the delivery end. Aluminum conveying equipment shall not be used.

3.4.8 Mud, soil or foreign matter shall be prevented from entering concrete or forms during placement operations.

3.4.9 Concrete in walls shall be placed continuously in level layers not exceeding two feet thick, so that no cold joints form. Prior to concrete placement, Contractor shall make arrangements to assure uninterrupted delivery of concrete.

3.4.10 Beams and floor slabs shall be placed in one continuous operation unless noted otherwise.

3.4.11 Grade beams, pedestals, columns, and walls shall be placed monolithic, without joints, unless noted otherwise.

3.4.12 Construction joints for walls shall be placed at maximum ten feet height unless noted otherwise

### 3.5 Consolidation

3.5.1 Concrete shall be compacted thoroughly into a dense homogeneous mass throughout entire depth of layer being consolidated.

3.5.2 Concrete for slabs, drilled piers, footings, and walls shall be consolidated by vibration, spading or rodding so that concrete is thoroughly worked around reinforcing steel, conduit, embedded items and into corners of forms. Manual consolidation methods for structural concrete placement shall not be used. Structural concrete slab surface shall not be hand tamped when concrete has four inch or greater slump

3.5.3 Adequate number of vibrators of sufficient capacity shall be provided to keep up with maximum rate of concrete placement. An adequate supply of standby equipment, including a minimum of one vibrator, shall be kept at jobsite

3.5.4 Internal vibrators shall be inserted vertically through the full depth of layer being placed, penetrating into the previous layer. Vibrator shall not be dragged, but inserted and withdrawn slowly with vibrator running continuously so that no void is left in concrete. Vibrator shall not be used to flow concrete from one location to another.

3 5 5 Concrete shall be vibrated until it is thoroughly consolidated and voids are filled as evidenced by level appearance of concrete at exposed surface and embedment of surface aggregate.

3 5.6 Form vibrators may be used only where sections are too thin or inaccessible for internal vibrators

### 3 6 Finishing

3 6.1 Concrete for foundations shall be finished so that free water will not collect on surface

3 6.2 Threads on anchor bolts and reinforcing steel dowels shall be protected from concrete buildup and/or splatter Threads on anchor bolts shall be cleaned so that nuts turn freely without interference

3 6.3 Exposed concrete surfaces for floor slabs shall have final finish conforming to ACI 302.1R unless noted otherwise

3 6.4 Floor slabs which are to be covered with resilient flooring or coatings shall have smooth, steel trowel finish.

3 6.5 Slabs on which concrete pedestals are to be placed shall have rough, scored finish.

3 6.6 All other exposed concrete surfaces shall have formed or smooth, steel trowel finish, unless noted otherwise.

3 6.7 Control joints may be formed or sawcut Sawcutting shall be done during initial setting of concrete, but in no case later than 12 hours after completion of concrete placement. Sawcut shall extend full design length. Wall and edge conflicts will preclude use of sawcutting

3 6.8 Exposed concrete shall be free from irregularities, fins, rock pockets, or other imperfections. Defective concrete surfaces including misalignment and holes from form ties, shall be repaired. Defective surfaces shall be repaired prior to placement of backfill Repairs to defective surfaces shall be made in following manner

- a. Surface shall be chipped back to minimum depth of one-half inch beyond imperfection. Edges shall be chipped perpendicular to surface, and the depression shall be pre-wetted and brushed with neat cement immediately before patching.

- b. Mortar used for patching shall have same sand-cement ratio as original concrete with minimum water for placing. Color of existing concrete shall be matched at exposed surfaces.
- c. Mortar to patch form-tie holes shall be applied with hammer and ramming rod within 24 hours of removal of wall forms and shall be struck flush.
- d. Repairs shall be cured by moistening for three days or by using curing compound.

### 3.7 Curing

3.7.1 Concrete surfaces shall be cured by methods recommended in ACI 308, ACI 305R or ACI 306.1. The following are acceptable methods:

- a. Using saturated burlap, soaker hoses, or sprinklers to keep concrete continuously wet for minimum seven days.
- b. Covering concrete with polyethylene sheets, other than black film, applied in full contact with surfaces and sealed around edges.
- c. Applying curing compound to unformed concrete surfaces within one hour after applying finish. Curing compound shall be applied to formed concrete within one hour after stripping forms. Where epoxy coating or staining of concrete is required, curing compound shall contain no waxes, paraffins or oils. Curing compound shall be applied by spraying with uniform coverage, at rate recommended by manufacturer.

3.7.2 Curing compound shall not be used on concrete surfaces which are to be in contact with grout. If curing compound is used, concrete surfaces shall be sandblasted prior to placing grout. Other means of surface cleaning, such as high pressure water blasting/water jetting, will also be acceptable.

3.7.3 If concrete shows tendency to set and dry too rapidly, form shrinkage cracks or form cold joints, concrete shall be kept moist using fog spray, wet burlap, cotton mats, or other method(s) acceptable to the Engineer.

3.7.4 Concrete placed during cold weather shall be protected with insulating blankets or heated enclosures. Fresh concrete shall not be exposed to carbon monoxide or carbon dioxide fumes from heaters or engines.

### 3.8 Form Removal

3.8.1 Forms shall not be relieved of load or removed without approval of the Engineer. Formwork for structural slabs shall not be removed until concrete has attained 70 percent specified minimum compressive design strength ( $f_c$ ) or until

seven days, whichever occurs first. Formwork for structural walls shall remain in place for minimum 24 hours after concrete placement. Side forms for nonstructural members may be removed, at Contractor's risk, after concrete has set.

3.8.2 70 percent specified minimum compressive design strength ( $f_c$ ) shall be required before backfilling against walls or application of loads.

### 3.9 Tolerances

Tolerances for concrete construction shall conform to ACI 117. Following tolerances are maximum, noncumulative, variations from dimensions shown on Contract Documents

- |    |  |                       |
|----|--|-----------------------|
| a  | Plumbness in lines and surfaces of concrete walls, columns and piers.  |                       |
|    | In any 10 feet   | 1/4 inch              |
|    | Maximum for total structure height   | 1/2 inch              |
| b  | Cross-sectional dimensions of columns, beams, walls and slab thickness:  |                       |
|    | Up to 12 inches  | + 3/8 inch/- 1/4 inch |
|    | More than 12 inches  | + 1/2 inch/- 3/8 inch |
| c  | Footings, Horizontal Dimensions  |                       |
|    | Formed Excavation  | + 2 inches/- 1/2 inch |
|    | Unformed Excavation  | + 3 inches            |
| d. | Minimum Concrete Cover:  |                       |
|    | Beams, Walls & Columns   | - 0 inch              |
| e  | Finished Slab Surfaces   |                       |
|    | Maximum depression in floors shall not exceed 3/16 inch below a 10 foot straightedge.  |                       |
| f  | Anchor bolts shall be plumb and to the following tolerances  |                       |
|    | Bolt projection  | +1/4 inch/- 0 inch    |
|    | Bolt location (without sleeves)  | ± 1/8 inch            |
|    | Bolt location (with sleeves)   | ± 3/16 inch           |
|    | Top of plastic anchor bolt sleeves shall be cut off flush with rough concrete just prior to grouting or setting equipment and base plates. |                       |

### 3.10 Quality Control

3.10.1 Reinforcing steel setting, embedded items, electrical grounding wires and form accessories will be inspected by the Engineer prior to concrete placement. Concrete shall not be placed until all items have been approved by

the Engineer Contractor shall bear cost of delays in concrete placement caused by not providing sufficient inspection time or for making corrections to comply with requirements.

3 10.2 Concrete Testing

- a The Engineer will furnish test equipment and trained personnel to perform required field tests and to make required test cylinders.
- b The Engineer shall be provided access and adequate time for securing samples to determine whether materials are in accordance with Contract Documents.
- c The Engineer may select and pay an independent testing laboratory to perform required laboratory tests.
- d Testing, strength compliance, and acceptance of concrete will be in accordance with SRP 03300
- e Contractor has right to observe all phases of concrete cylinder fabrication, curing and testing Should Contractor observe deviations from the prescribed testing procedure that may be detrimental to concrete strength test results, Contractor shall immediately notify the Engineer
- f. The Engineer may require modifications of materials on the basis of field or laboratory tests Contractor shall make such modifications at his own expense.

3 10 3 Contractor shall have sole responsibility for meeting concrete placement requirements Inspection by the Engineer shall not relieve Contractor of responsibility for errors or deviations from specifications

3 10 4 Concrete rejected by the Engineer for nonconformance shall be corrected to conform to specifications or removed and replaced. Contractor shall be responsible for direct and indirect costs of correction, removal and replacement of rejected concrete, including costs incurred by the Engineer

# **REFERENCE DRAWINGS**



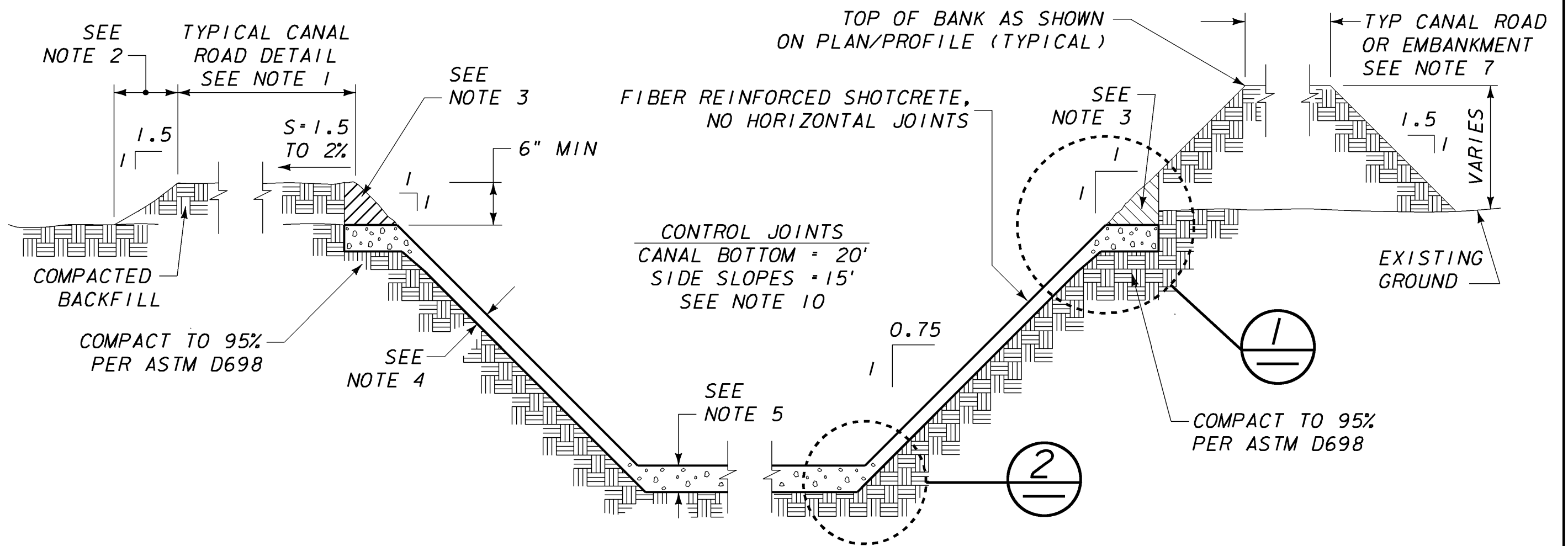

## TYPICAL CANAL SECTION

SEE DETAIL ③ AND ④ FOR TIE-IN TO EXISTING LINING

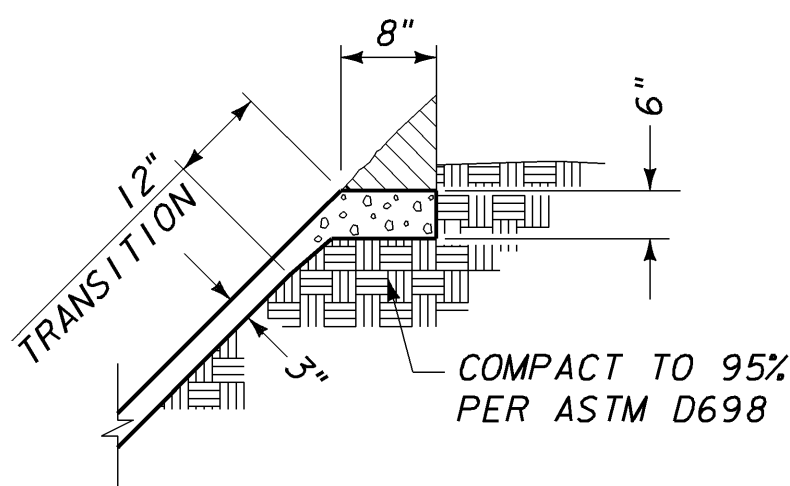

DETAIL ①

TRANSITION THE CANAL BOTTOM LINING AT A 4:1 MAXIMUM SLOPE FROM THE EXISTING LINING ELEVATION TO THE NEW LINING FINISH GRADE ELEVATION

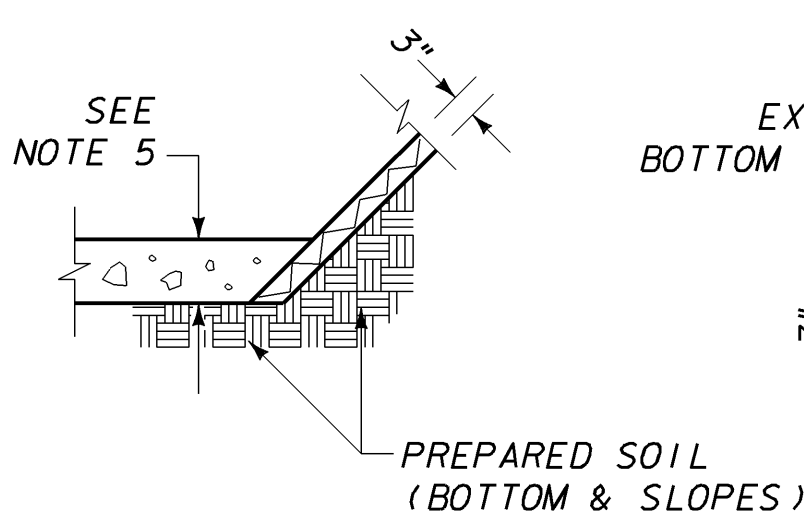

DETAIL ②  
OPTION 1

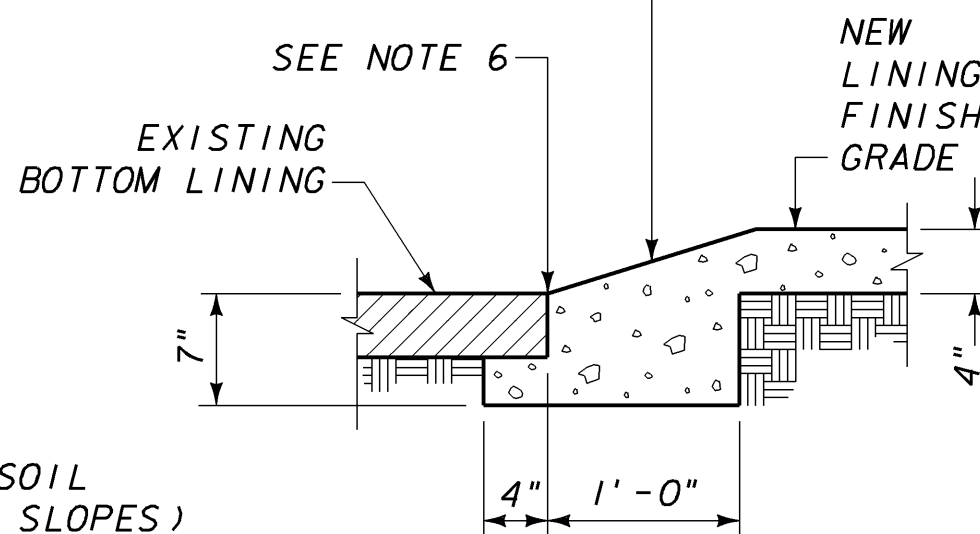

DETAIL ③  
SEE NOTE 6

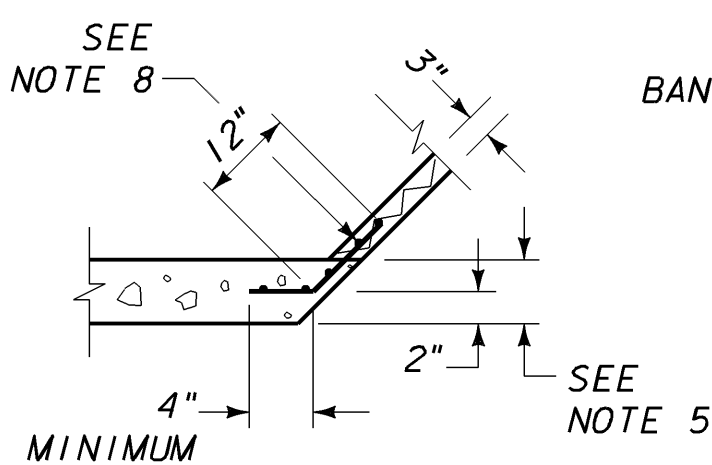

DETAIL ②  
OPTION 2

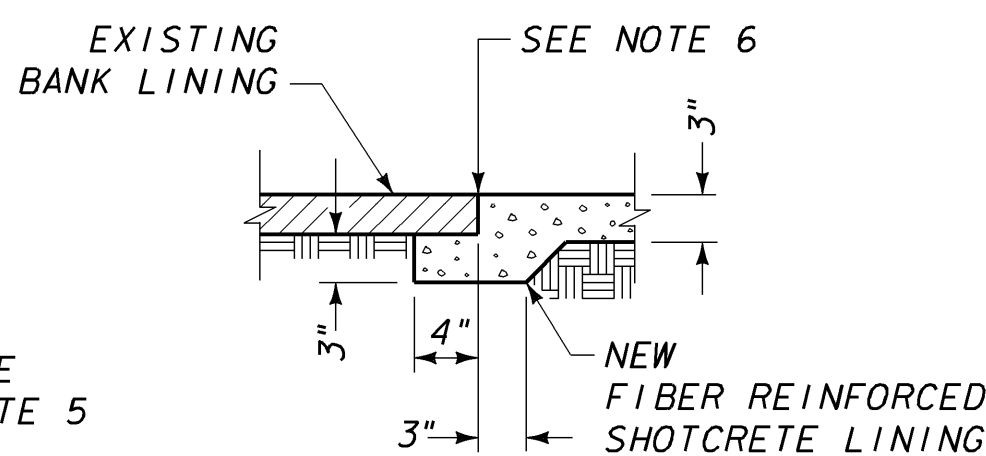

DETAIL ④  
SEE NOTE 6

## NOTES

1. WIDTH OF CANAL ROAD TO BE 20' MINIMUM UNLESS OTHERWISE SPECIFIED. STRIP ROADWAY OF ALL VEGETATION AND LOOSE MATERIAL WITHIN THE LIMITS OF CONSTRUCTION, AND MOISTEN PRIOR TO PLACEMENT OF SUITABLE FILL MATERIAL. FILL SHALL BE PLACED IN 8 INCH MAXIMUM UNCOMPACTED LIFTS AT +2% TO -4% OF THE OPTIMUM MOISTURE CONTENT AND COMPACTED TO A MINIMUM OF 90% PER ASTM D698. SLOPE AWAY FROM CANAL AT 1.5% TO 2%.
2. TOE OF SLOPE TO BE WITHIN THE RIGHT-OF-WAY OR OTHER PRESCRIBED LIMITS OF CONSTRUCTION.
3. TOP OF EXISTING BANKS TO BE STRIPPED OF ALL VEGETATION AND LOOSE MATERIAL. BACKFILL WITH MOISTENED COHESIVE MATERIAL. STABILIZE TO PREVENT SLOUGHING.
4. MINIMUM 3 INCH THICK PNEUMATICALLY PLACED FIBER REINFORCED SHOTCRETE BANK LINING PER SPECIFICATION SRP 03364. FIBER REINFORCEMENT SHALL COMPLY WITH THE REQUIREMENTS OF ASTM C1116.
5. CANAL BOTTOM TO BE MINIMUM 4 INCHES THICK NON-REINFORCED CONCRETE (3000 PSI).
6. CUT EXISTING LINING TO A NEAT VERTICAL EDGE. REMOVE ANY LOOSE OR FOREIGN MATERIAL. APPLY BONDING AGENT SIKADUR 32 OR APPROVED EQUAL.
7. WHERE CANAL HAS ONLY EMBANKMENT ON ONE SIDE, MINIMUM TOP WIDTH OF EMBANKMENT SHALL BE 18".
8. GALVANIZED 4 X 4-WO.5 X WO.5 WELDED WIRE FABRIC CONTINUOUS CENTERED IN LINING.
9. DETAIL 2 (OPTION 2) IS PREFERRED BY ENGINEER.
10. CONTROL JOINT SHALL BE 1/4" WIDE AND 1/2" DEEP, AND BE TOOLED OR SAW CUT WITHIN 4 HOURS OF CONCRETE PLACEMENT. MAXIMUM SPACING BETWEEN CONTROL JOINTS SHALL BE 20' ON CANAL BOTTOM AND 15' ON SIDE SLOPES, UNLESS OTHERWISE SHOWN ON THE DRAWINGS OR DIRECTED IN WRITING BY THE ENGINEER.
11. IF THERE ARE CONFLICTS WITH THIS DETAIL, PLANS AND SPECIFICATIONS AND LOCAL GOVERNING REQUIREMENTS, THE MOST STRINGENT REQUIREMENT SHALL APPLY, AS DETERMINED BY THE SRP ENGINEER.

## REFERENCES

STANDARD SPEC FOR PREPARATION OF SUBGRADE FOR CANAL LINING	CE 02.490
STANDARD SPEC FOR CANAL BANK REINFORCEMENT	CE 03.212
STANDARD SPECIFICATION FOR CONCRETE	SRP 03300
STANDARD SPEC FOR PLACEMENT OF CANAL BOTTOM CONCRETE	CE 03.361
STANDARD SPEC FOR FIBER REINFORCED SHOTCRETE FOR CANAL BANK LINING	SRP 03364
SAFETY LADDER FOR CONCRETE LINED CANALS	WES-30100-001
CANAL LINING STRUCTURE TIE DETAIL	WES-30100-008

## REVISIONS

REV NO.	DFTR	DSGN	ENGR CHK	ISSUE AUTH	DATE
5	JWS	HAS	HAS	REL	02/22/19
0	JWS	RSG	CWT	REL	01/31/00

REVISED CONTROL JOINT SPACING ON SIDE SLOPE TO 15' ON SECTION/NOTE 10. ADDED NOTE 11 & JOINT WIDTH/DEPTH TO NOTE 10.

INITIAL ISSUE.

**SALT RIVER PROJECT**  
WATER ENGINEERING STANDARD

## FIBER REINFORCED CANAL LINING SECTION

SCALE: NOT TO SCALE FRCANLING.WES

DWG SIZE  
22X17

**WES-FRCANLING**

NATIVE BACKFILL COMPACTED TO 95% +/- 2% OPTIMUM MOISTURE CONTENT, OR MORE STRINGENT AND APPROVED BY ENGINEER

MAG 702 ABC (SRP-0113)  
MIN 95% COMPACTION  
+/- 2% MOISTURE CONTENT,  
OR MAG 728 1/2-SACK CLSM  
(SRP-00-0104)

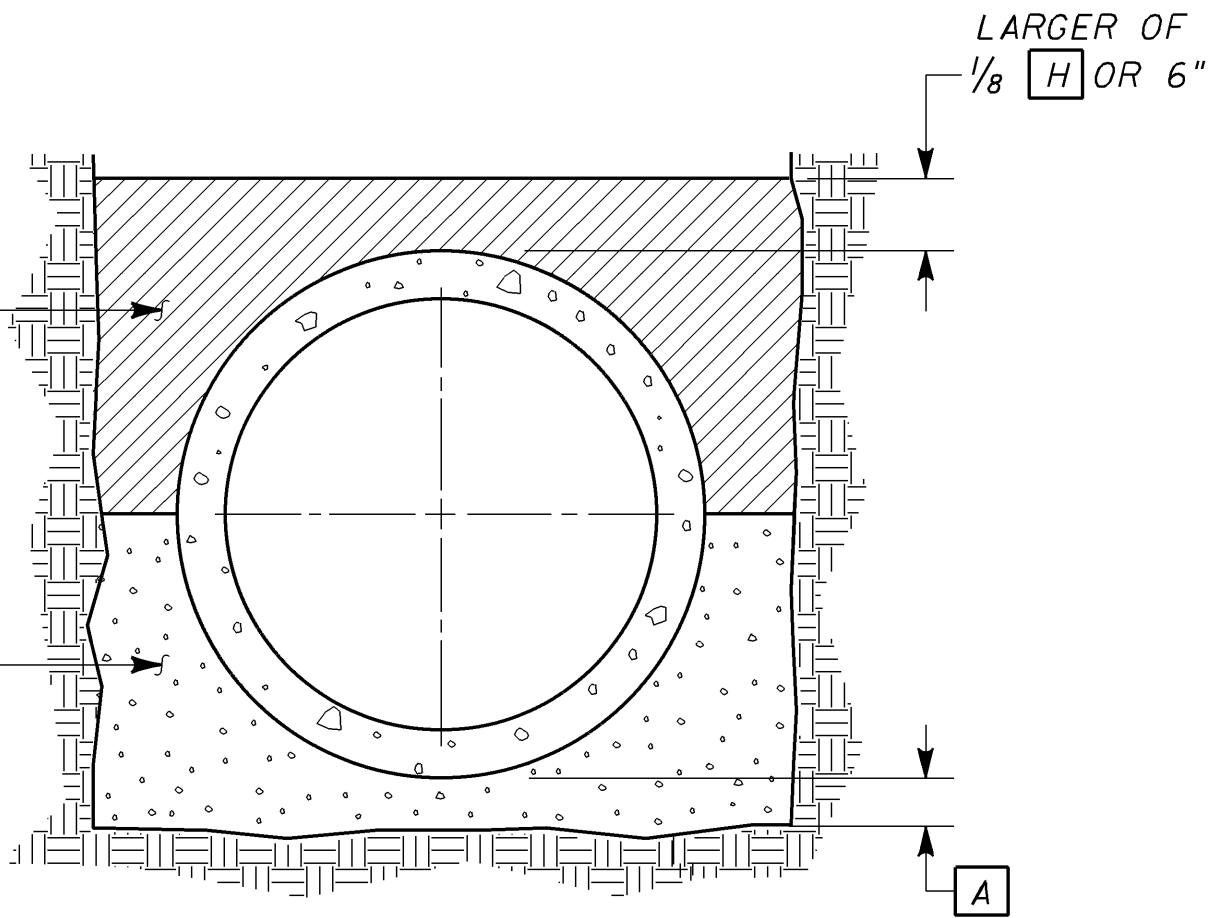

### TYPICAL BEDDING

LOAD FACTOR 1.9

NATIVE BACKFILL COMPACTED TO 95% +/- 2% OPTIMUM MOISTURE CONTENT, OR MORE STRINGENT AND APPROVED BY ENGINEER

MAG 702 ABC (SRP-0113)  
MIN 95% COMPACTION  
+/- 2% MOISTURE CONTENT,  
OR MAG 728 1/2-SACK CLSM  
(SRP-00-0104)

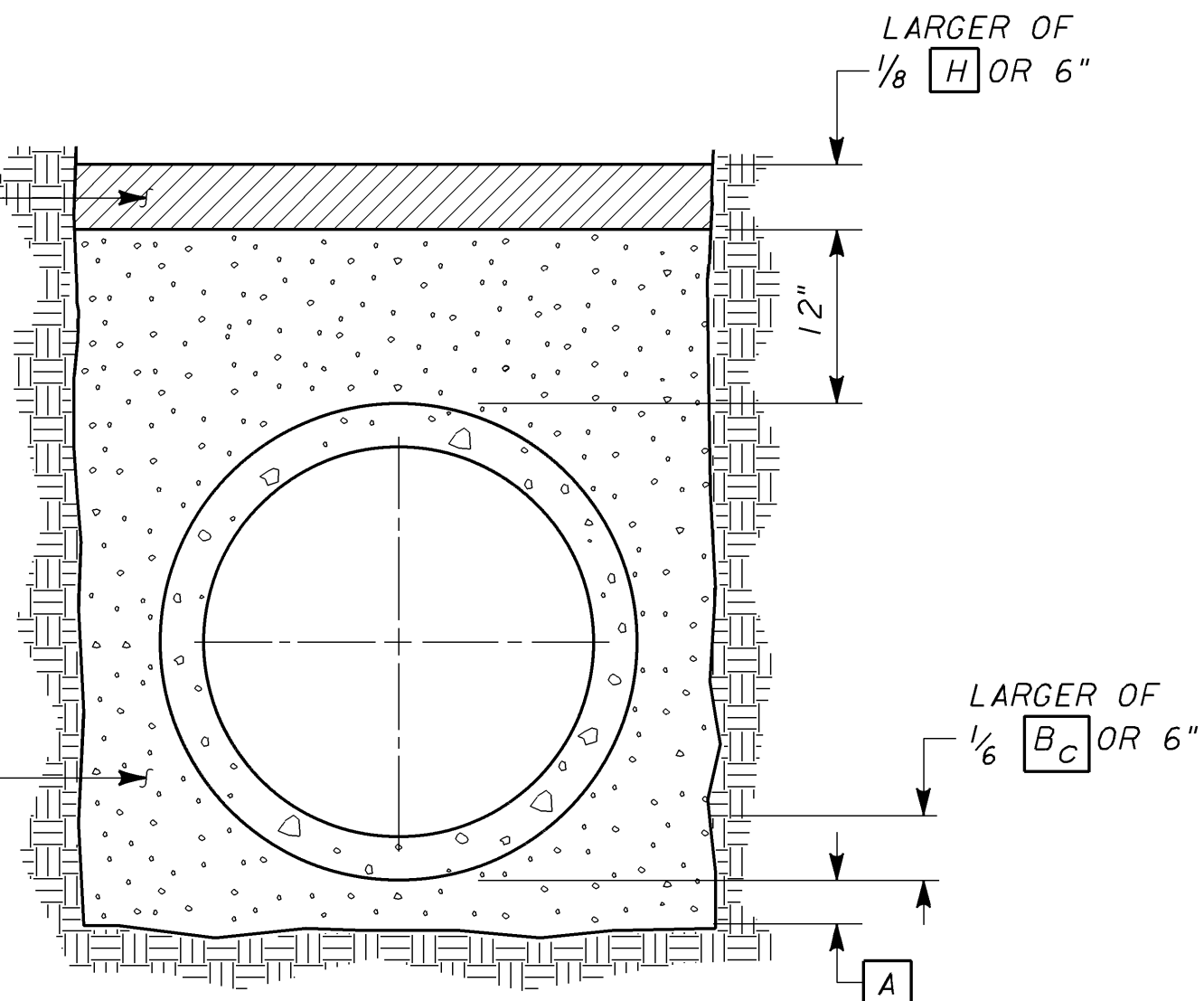

### TRAFFIC LOADED BEDDING

#### NOTES:

1. ABC REQUIRES COMPACTION IN 12 INCH LIFTS.
2. ABC CANNOT BE USED BETWEEN BEDDING & SPRINGLINE.

#### TABLE OF FILL DEPTHS BELOW PIPE

PIPE DIAMETER	$\boxed{A}$ MINIMUM
36" & SMALLER	4"
OVER 36"	$\frac{1}{12}$ OF $\boxed{B_C}$

$\boxed{H}$  = DEPTH OF FILL ABOVE TOP OF PIPE  
 $\boxed{B_C}$  = OUTSIDE DIMENSION OF PIPE

#### REFERENCES

PRECAST CONCRETE PIPE SPECIFICATION \_\_\_\_\_ WTR 02614

#### REVISIONS

REV NO	DATE	DFTR	CHKR	ENGR CHK	SUPV APPD	ISSUE AUTH
REVISED BACKFILL AND GRANULAR FILL REQUIREMENT TO MAG SPECIFICATION.						
3	04/30/22	JWS	BRM	CMA	-	AWJ
ADDED CONCRETE ENCASEMENT NOTE AND REMOVED METRIC REFERENCES.						
2	10/28/03	JWS	-	CWT	-	REL
INITIAL ISSUE.						
0	2/89	AK	WJC	REL	AAR	TNS

SALT RIVER PROJECT  
WATER ENGINEERING STANDARDS

## PIPELINE BEDDING/BACKFILL REQUIREMENTS

SCALE: NONE

30300001.WES

DWG SIZE

17 X 22

WES-30300-001

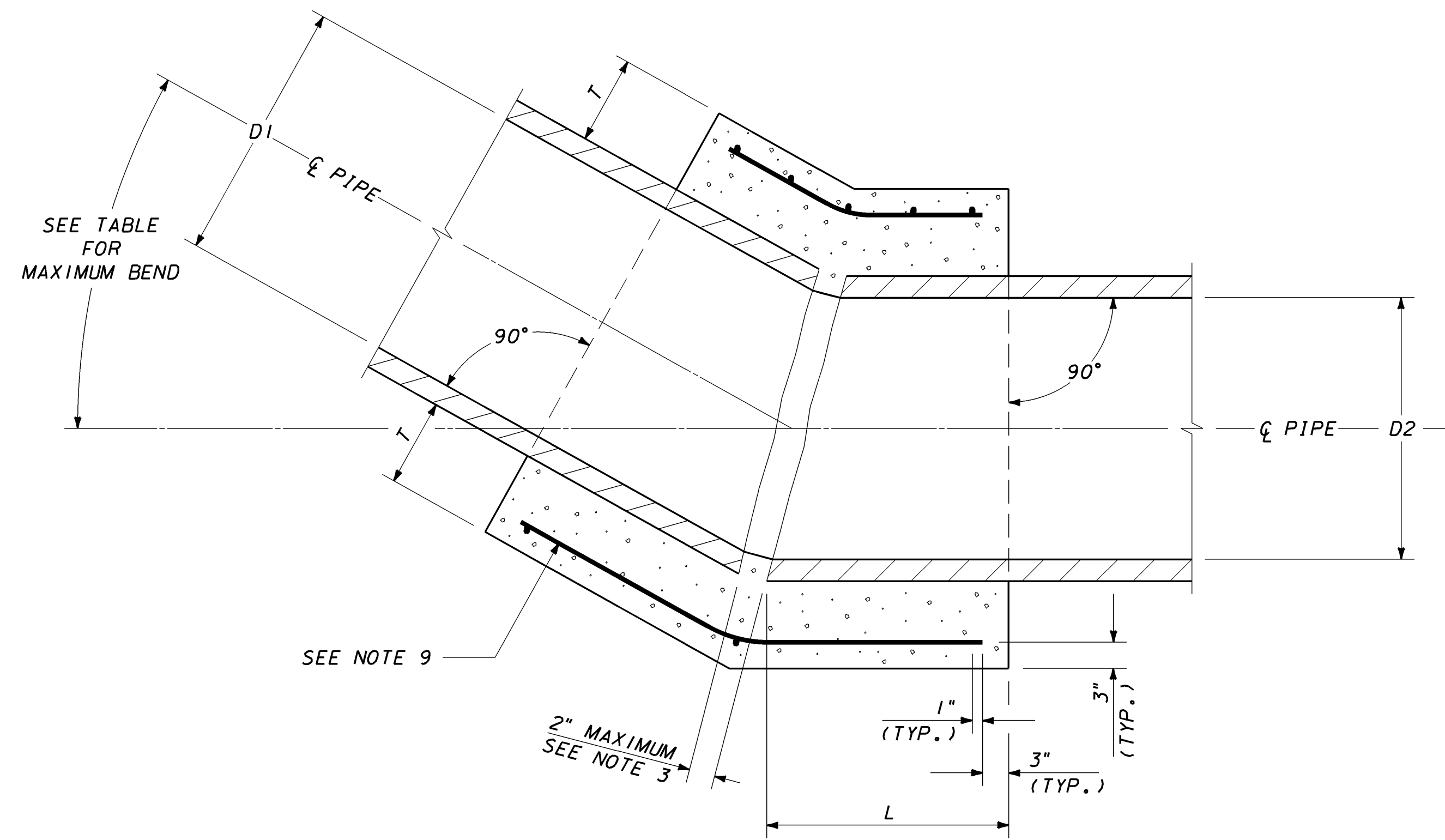

**PIPE COLLAR DETAIL**

**MINIMUM REQUIREMENTS**

D	L	T	REINFORCING STEEL	MAXIMUM BEND		
12"	12"	6"	(3) #4 HOOPS WITH #4 @ 12" OR 6x6-W5.5xW5.5 WWF	22 1/2°		
18"				30°		
24"						
30"	18"	8"		(3) #4 HOOPS WITH #4 @ 12" OR 6x6-W5.5xW5.5 WWF	45°	
36"						
42"						
48"						
54"	24"	10"			(3) #4 HOOPS WITH #4 @ 12" OR 6x6-W5.5xW5.5 WWF	45°
60"						
66"						
72"						
78"	30"	12"	(3) #4 HOOPS WITH #4 @ 12" OR 6x6-W5.5xW5.5 WWF			45°
84"						
90"						
96"	36"	14"		(3) #4 HOOPS WITH #4 @ 12" OR 6x6-W5.5xW5.5 WWF		45°
102"						
108"						

D = D1 OR D2, WHICHEVER IS GREATER. (SEE NOTE 4)

**NOTES**

- NO SUBSTITUTIONS AND/OR CHANGES SHALL BE MADE WITHOUT ENGINEER'S APPROVAL.
- CONCRETE PIPE COLLAR IS REQUIRED TO JOIN TWO PLAIN END PIPES OF DIFFERENT DIAMETERS, MATERIALS, OR PIPES AT CHANGE IN ALIGNMENT OR GRADE.
- PIPE ENDS SHALL BE TRIMMED SUCH THAT THE MAXIMUM DISTANCE BETWEEN PIPES AT ANY POINT IS TWO INCHES.
- MINIMUM PIPE COLLAR SIZE SHALL CORRESPOND TO LARGER OF THE TWO PIPE DIAMETERS.
- CONCRETE COLLARS SHALL BE FINISHED SMOOTH AND FLUSH WITH THE INSIDE SURFACE OF THE PIPE.
- CONCRETE SHALL CONFORM TO REQUIREMENTS OF SRP STANDARD SPECIFICATION FOR CONCRETE (SRP 03300).
- CONCRETE SHALL HAVE A MINIMUM COMPRESSIVE STRENGTH OF 3000 PSI @ 28 DAYS (MAG A) AND SHALL BE CONSOLIDATED BY MECHANICAL VIBRATOR OR EQUIVALENT.
- REINFORCING STEEL SHALL CONFORM TO ASTM A615 GRADE 60 AND WELDED WIRE FABRIC SHALL BE ASTM 185.
- THE DIAMETER OF WELDED WIRE FABRIC OR REBAR HOOPS SHALL BE THE OUTSIDE DIAMETER OF THE PIPE PLUS "T". LAP SHALL BE 12".
- ALL FORMS SHALL BE REMOVED PRIOR TO BACKFILLING.
- STANDARD CONCRETE PIPE COLLAR SHALL NOT BE USED UNDER PAVEMENT SURFACES.

**REFERENCES**

**REVISIONS**

**SRP SALT RIVER PROJECT WATER ENGINEERING STANDARD**

REV NO.	DFTR	DSGN	ENGR CHK	ISSUE AUTH	DATE
REVISED REBAR DIMENSION AND LOCATION ON THE PIPE COLLAR DETAIL.					
5	JWS	CMA	BRM	AWJ	04/30/22
REVISED DETAIL, NOTES, TABLE (REMOVED METRIC DIMENSIONS) & DRAWING SIZE.					
4	JWS	-	CWT	REL	02/09/01
	JWS	-	CWT	REL	

**STANDARD CONCRETE PIPE COLLAR SECTION AND DETAILS**

SCALE: NONE  
30300003.WES

DWG SIZE: 22X34

**WES-30300-003**

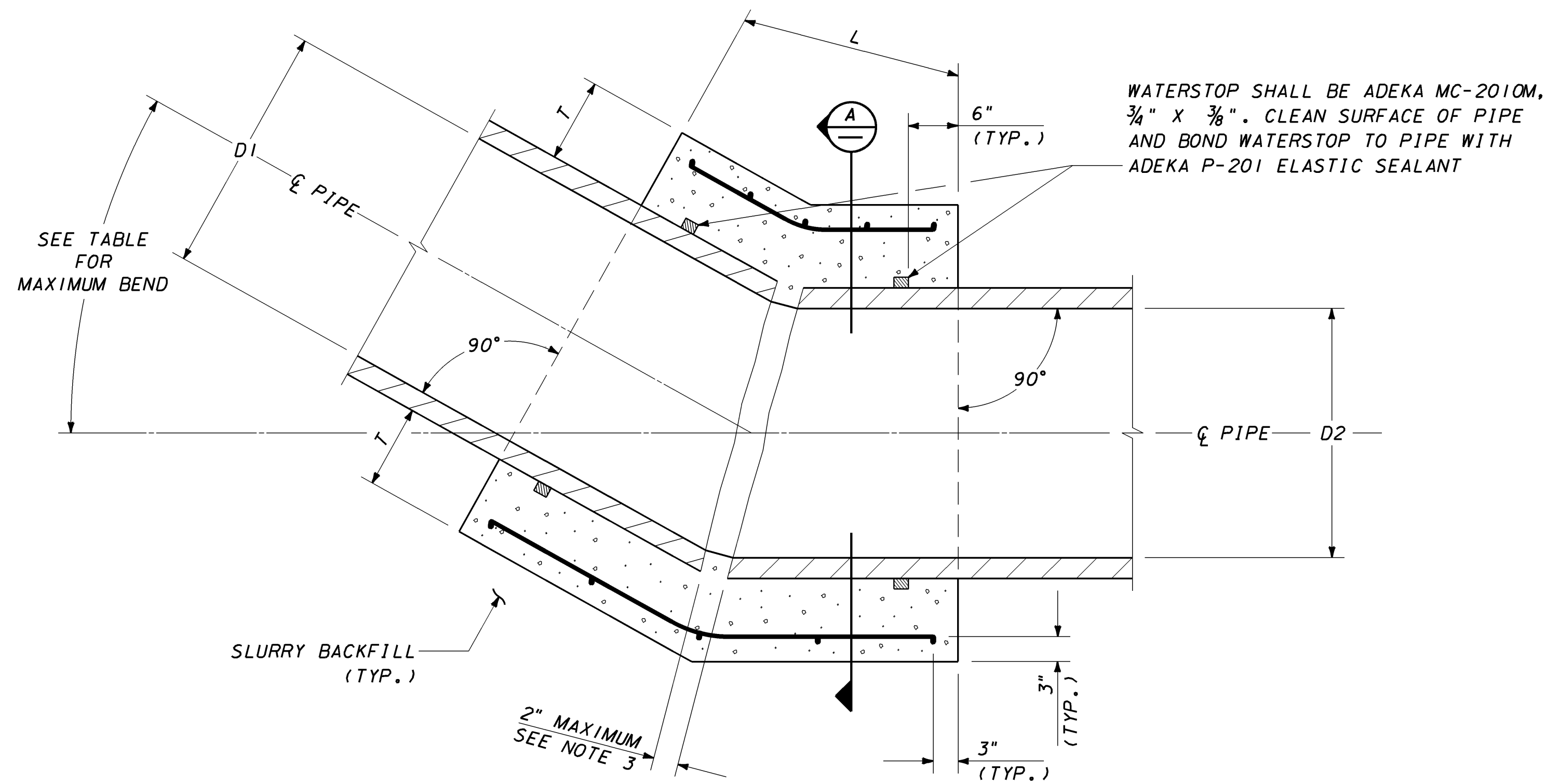

**PIPE COLLAR DETAIL**  
NTS

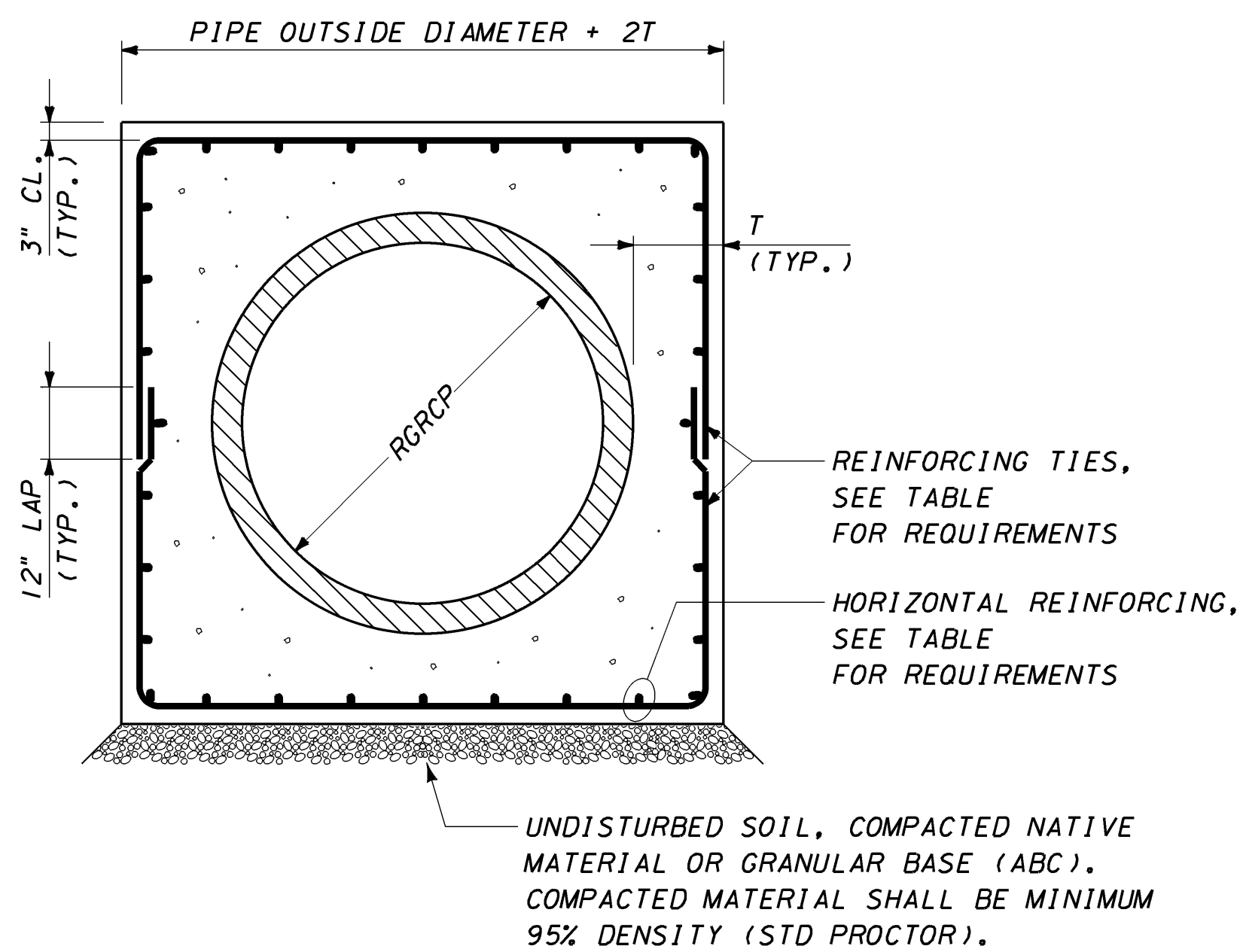

**SECTION A**  
NTS

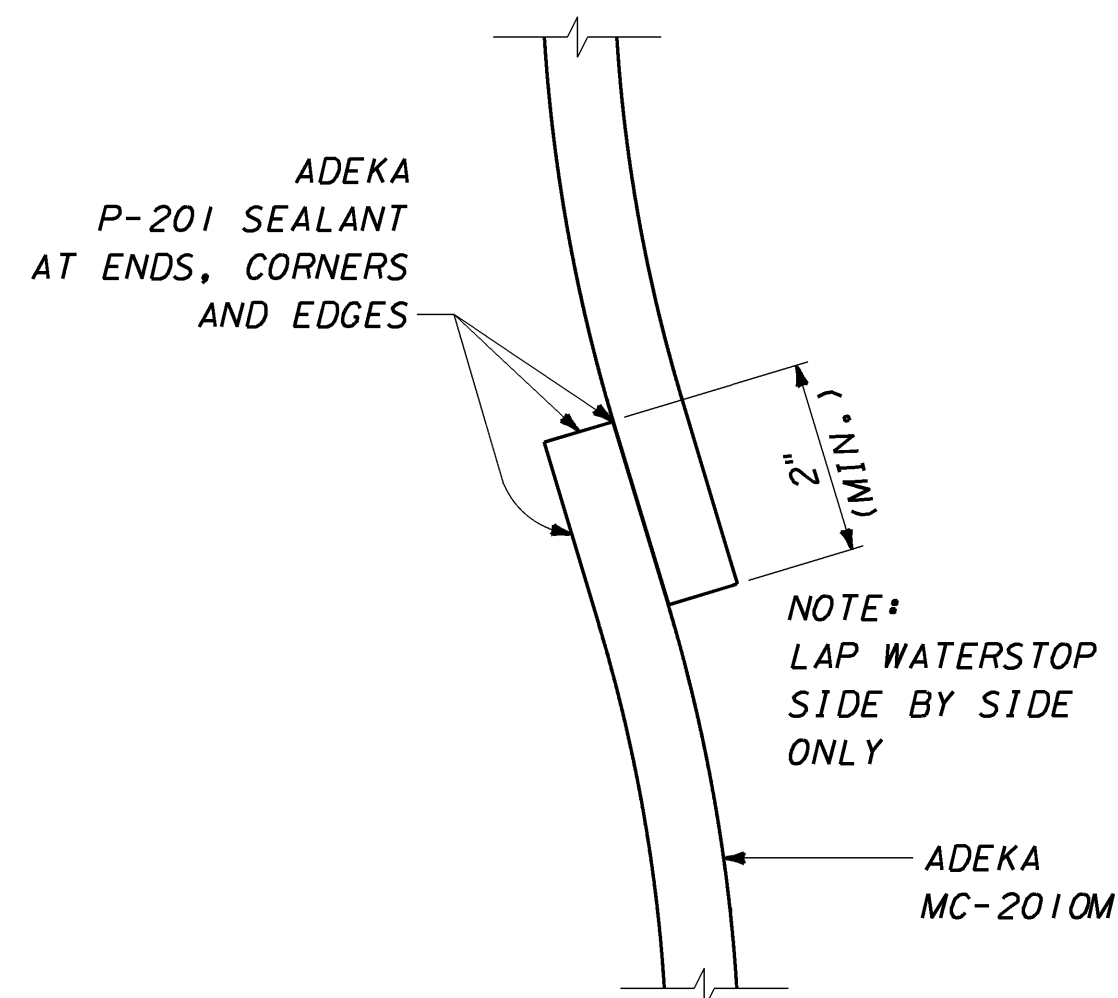

**WATERSTOP LAP DETAIL**  
NTS

**MINIMUM REQUIREMENTS**

D	L	T	REINFORCING STEEL	MAXIMUM BEND
12"	36"	10"	(4) #4 TIES AND #4 HORIZONTAL @ 12"	22 1/2°
18"				30°
24"				
30"				
36"				
42"	48"	15"	(5) #5 TIES AND #5 HORIZONTAL @ 12"	45°
48"				
54"				
60"				
66"				
72"				
78"				
84"				
90"				
96"				
102"				
108"				

D = D1 OR D2, WHICHEVER IS GREATER. (SEE NOTE 4)

**NOTES**

- NO SUBSTITUTIONS AND/OR CHANGES SHALL BE MADE WITHOUT ENGINEER'S APPROVAL.
- CONCRETE PIPE COLLAR IS REQUIRED TO JOIN TWO PLAIN END PIPES OR PIPES AT CHANGE IN ALIGNMENT OR GRADE.
- PIPE ENDS SHALL BE TRIMMED SUCH THAT THE MAXIMUM DISTANCE BETWEEN PIPES AT ANY POINT IS TWO INCHES.
- MINIMUM PIPE COLLAR SIZE SHALL CORRESPOND TO LARGER OF THE TWO PIPE DIAMETERS.
- CONCRETE COLLARS SHALL BE FINISHED SMOOTH AND FLUSH WITH THE INSIDE SURFACE OF THE PIPE.
- CONCRETE SHALL CONFORM TO REQUIREMENTS OF SRP STANDARD SPECIFICATION FOR CONCRETE (SRP 03300).
- CONCRETE SHALL HAVE A MINIMUM COMPRESSIVE STRENGTH OF 4000 PSI @ 28 DAYS (MAG AA) AND SHALL BE CONSOLIDATED BY MECHANICAL VIBRATOR OR EQUIVALENT.
- CONCRETE CONSTRUCTION SHALL CONFORM TO SRP STANDARD SPECIFICATION FOR CONCRETE FORMWORK AND PLACEMENT (GE 03305).
- REINFORCING STEEL SHALL CONFORM TO ASTM A615 GRADE 60.
- REINFORCING STEEL SHALL BE DETAILED, FABRICATED AND PLACED IN ACCORDANCE WITH SRP STANDARD SPECIFICATION FOR REINFORCING STEEL (SRP 03210).
- ALL FORMS SHALL BE REMOVED PRIOR TO BACKFILLING.

**REFERENCES**

**REVISIONS**

REV NO.	DFTR	DSGN	ENGR CHK	ISSUE AUTH	DATE
REVISED REBAR DIMENSION AND LOCATION ON THE PIPE COLLAR DETAIL.					
1	JWS	CMA	BRM	AWJ	04/30/22
INITIAL ISSUE.					
0	JWS	JP	LAB	REL	10/25/00

**SALT RIVER PROJECT**  
WATER ENGINEERING STANDARD

**STRUCTURAL CONCRETE PIPE COLLAR SECTION AND DETAILS**

SCALE: NONE [120236]SP1PECLR.WES

DWG SIZE  
22X34

**WES-SPIPECLR**

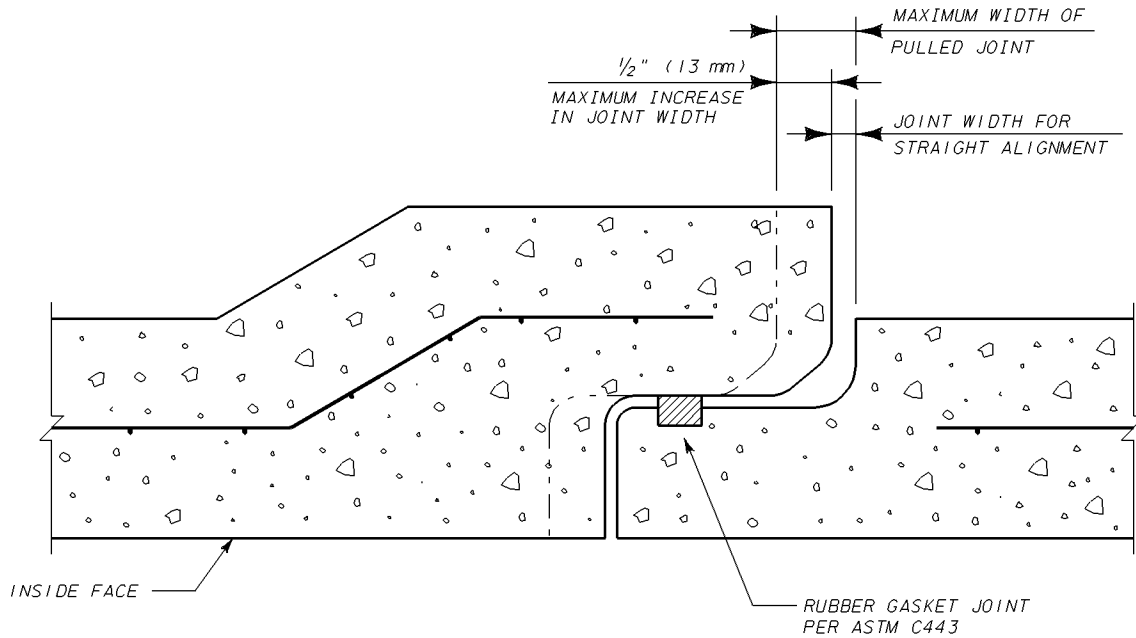

SECTION THRU PIPE JOINT

NOTES:

1. THIS DETAIL IS FOR A TYPICAL RUBBER GASKET BELL & SPIGOT ASSEMBLY. FLUSH BELL RUBBER GASKET JOINTS MUST MEET THE SAME SPECIFICATIONS.

REFERENCES		REVISIONS							SALT RIVER PROJECT WATER ENGINEERING STANDARDS	
PRECAST CONCRETE PIPE SPECIFICATION _____ WTR 02614		REV NO	DATE	DFTR	CHKR	ENGR CHK	SUPV APPD	ISSUE AUTH	<b>RUBBER GASKET JOINTS</b>	
		INITIAL ISSUE								
		0	2/89	AK	WJC	REL	AAR	TNS		
		REVISED TO ASTM C433 STANDARD								
		1	5/97	MD	---	CWT	---	REL	SCALE: NONE	P02: [ 120, 236] 30300004. WES
									DWG SIZE	WES-30300-004
									17 x 22	

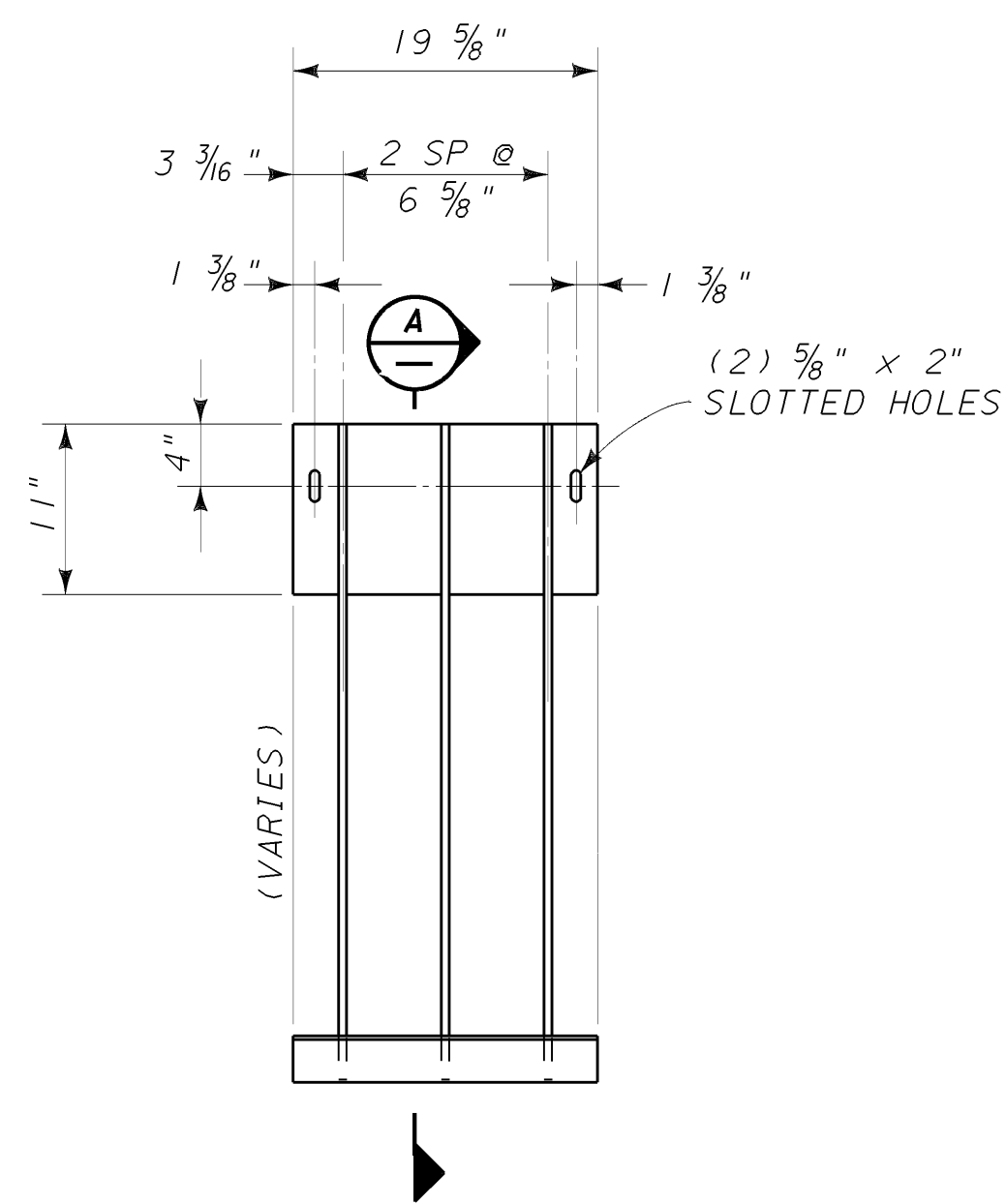

TRASHRACK-TYPE I

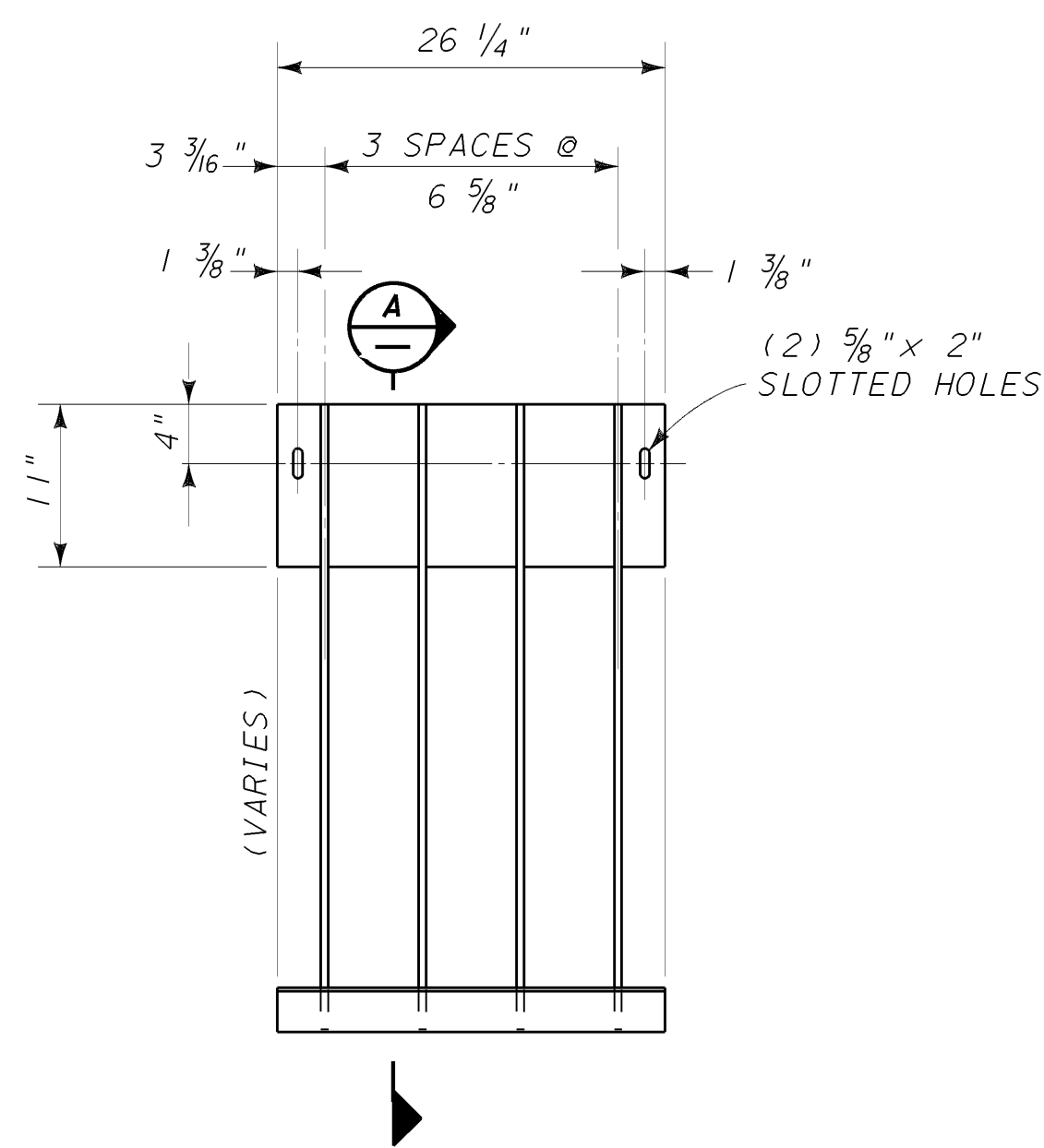

TRASHRACK-TYPE II

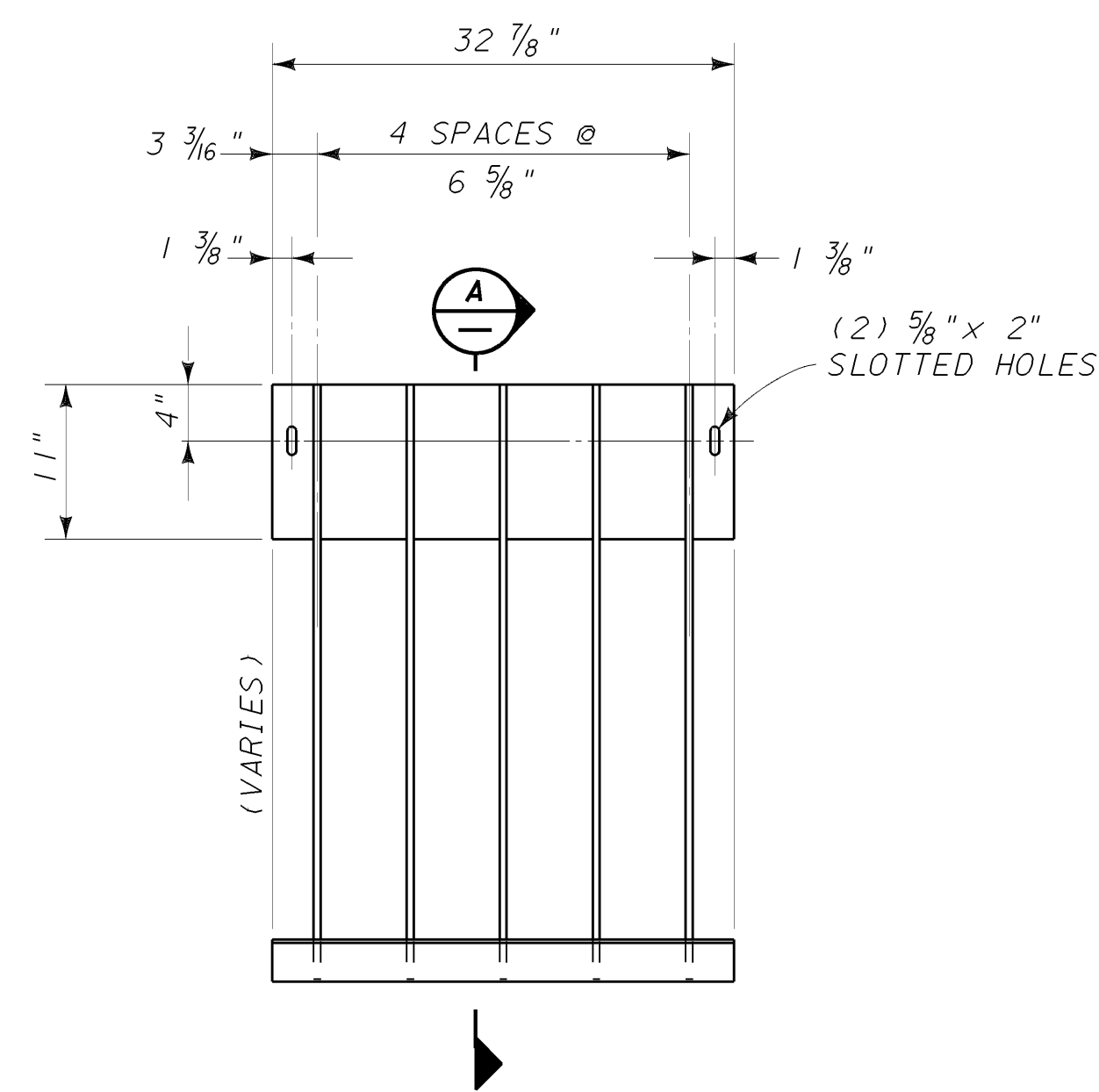

TRASHRACK-TYPE III

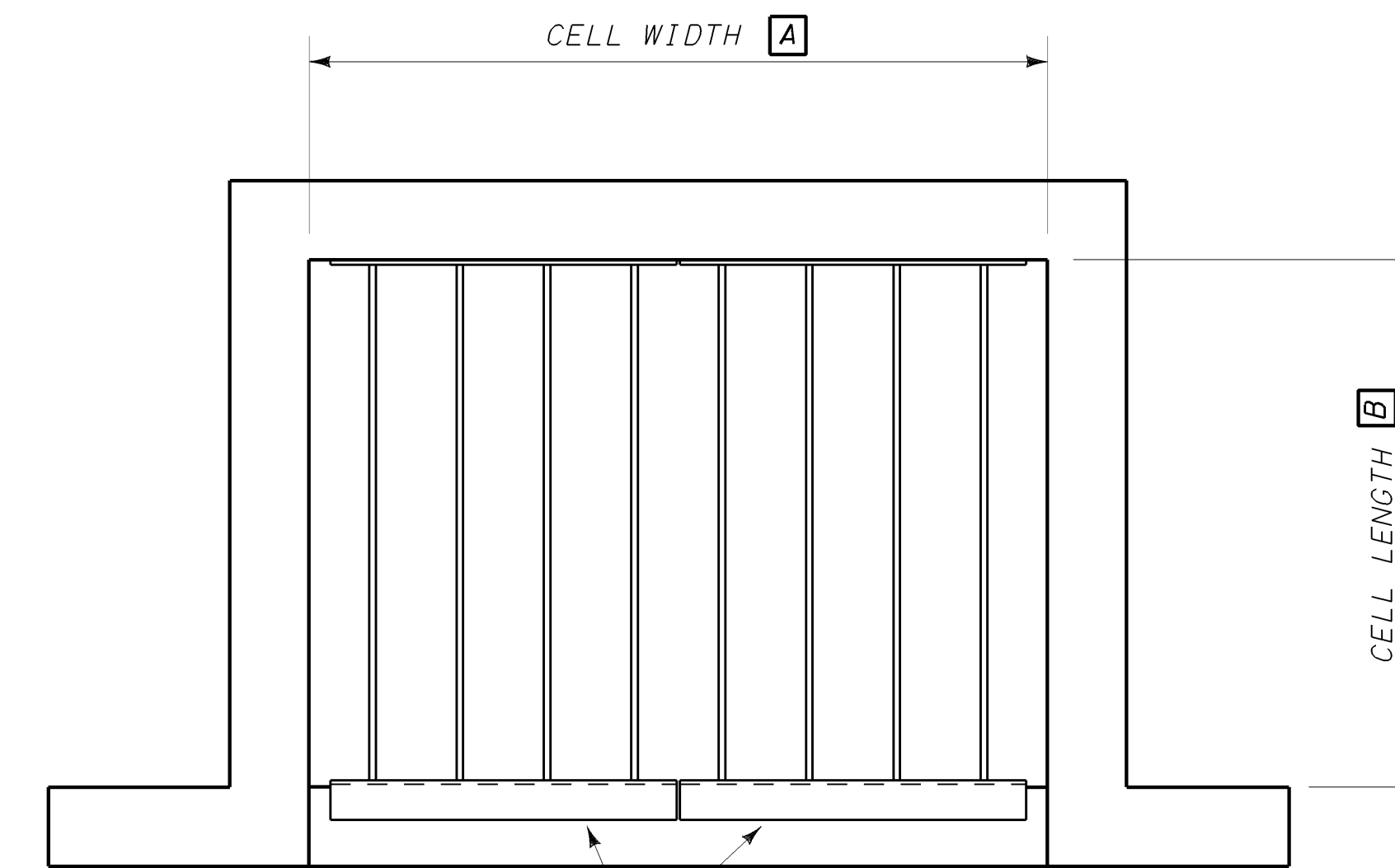

SEE TRASHRACK SCHEDULE FOR NUMBERS AND TYPES OF TRASHRACKS REQUIRED FOR VARYING CELL WIDTHS

HEADWALL KEY PLAN

TRASHRACK SCHEDULE			
HEADWALL CELL WIDTH [A]	NUMBER OF PANELS REQUIRED		
	TYPE I	TYPE II	TYPE III
32"	-	1	-
40"	-	-	1
48"	1	1	-
56"	-	2	-
64"	-	1	1
72"	-	-	2
80"	1	2	-
88"	-	2	1
96"	-	1	2
108"	2	-	2
120"	-	2	2
132"	-	1	3
144"	2	-	3
156"	1	-	4
168"	-	-	5
180"	1	1	4
192"	1	-	5

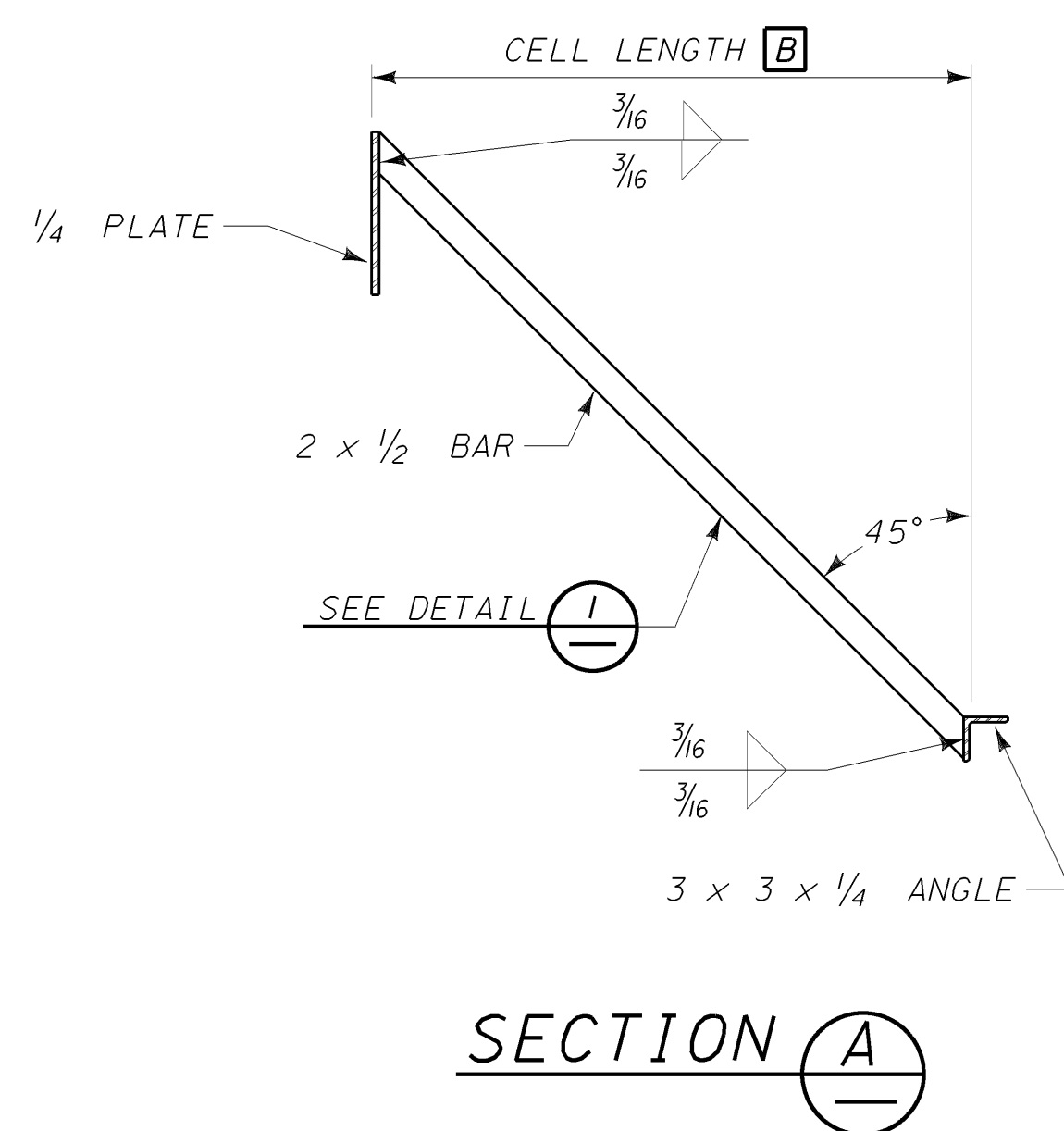

SECTION A

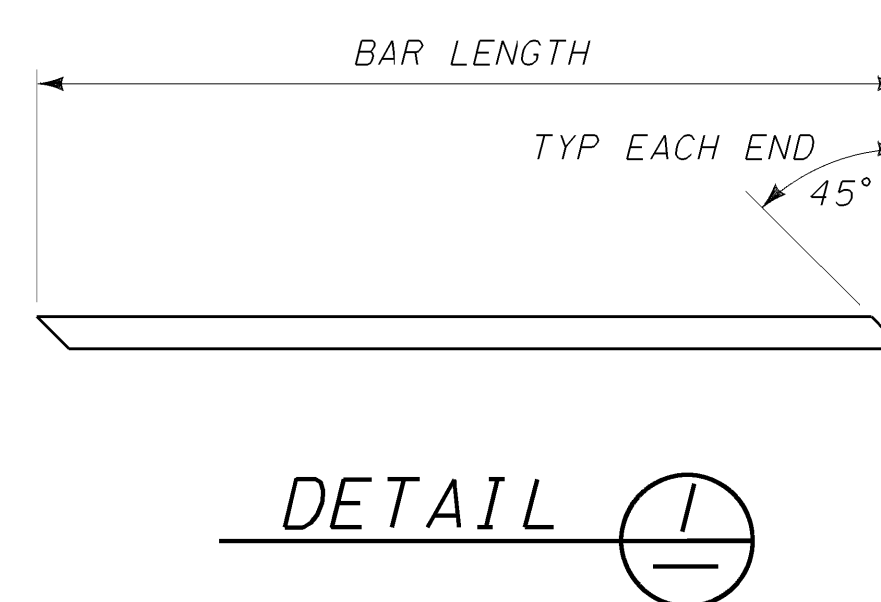

DETAIL 1

TRASHRACK BAR LENGTH SCHEDULE	
HEADWALL CELL LENGTH [B]	BAR LENGTH
16"	23 15/16"
24"	35 1/4"
32"	46 9/16"
40"	57 7/8"
48"	69 3/16"
56"	80 1/2"

**CONTRACTOR NOTE:**

TRASHRACK(S) MUST BE MANUFACTURED PRIOR TO REQUESTING AN IRRIGATION OUTAGE FOR THIS JOB.

**NOTES:**

- UNLESS OTHERWISE SPECIFIED, TOLERANCE DIMENSIONS SHALL BE +/- 1/32".
- ALL STEEL SHALL BE ASTM A36 UNLESS OTHERWISE NOTED.
- SANDBLAST TO NEAR WHITE AND ZINC METAL SPRAY OR HOT DIP GALVANIZE 5-7 MILS AFTER FABRICATION.

REFERENCES		REVISIONS						SALT RIVER PROJECT WATER ENGINEERING STANDARD	
		REV NO.	DFTR	DSGN	ENGR CHK	ISSUE AUTH	DATE	<p><b>45° TRASHRACK FOR PIPELINE HEADWALL</b></p>	
REMOVED MCM CONTACT/QUOTE INFO FROM CONTRACTOR NOTE.									
4	JWS	-	-	REL		08/20/18			
INITIAL ISSUE.								SCALE: NONE	30350200.WES
0	MOD	CWT	MLK	REL		02/22/95	DWG SIZE	22X34	WES-30350-200

# **REFERENCE LANDFILLS**



# SRP APPROVED LANDFILLS 2013

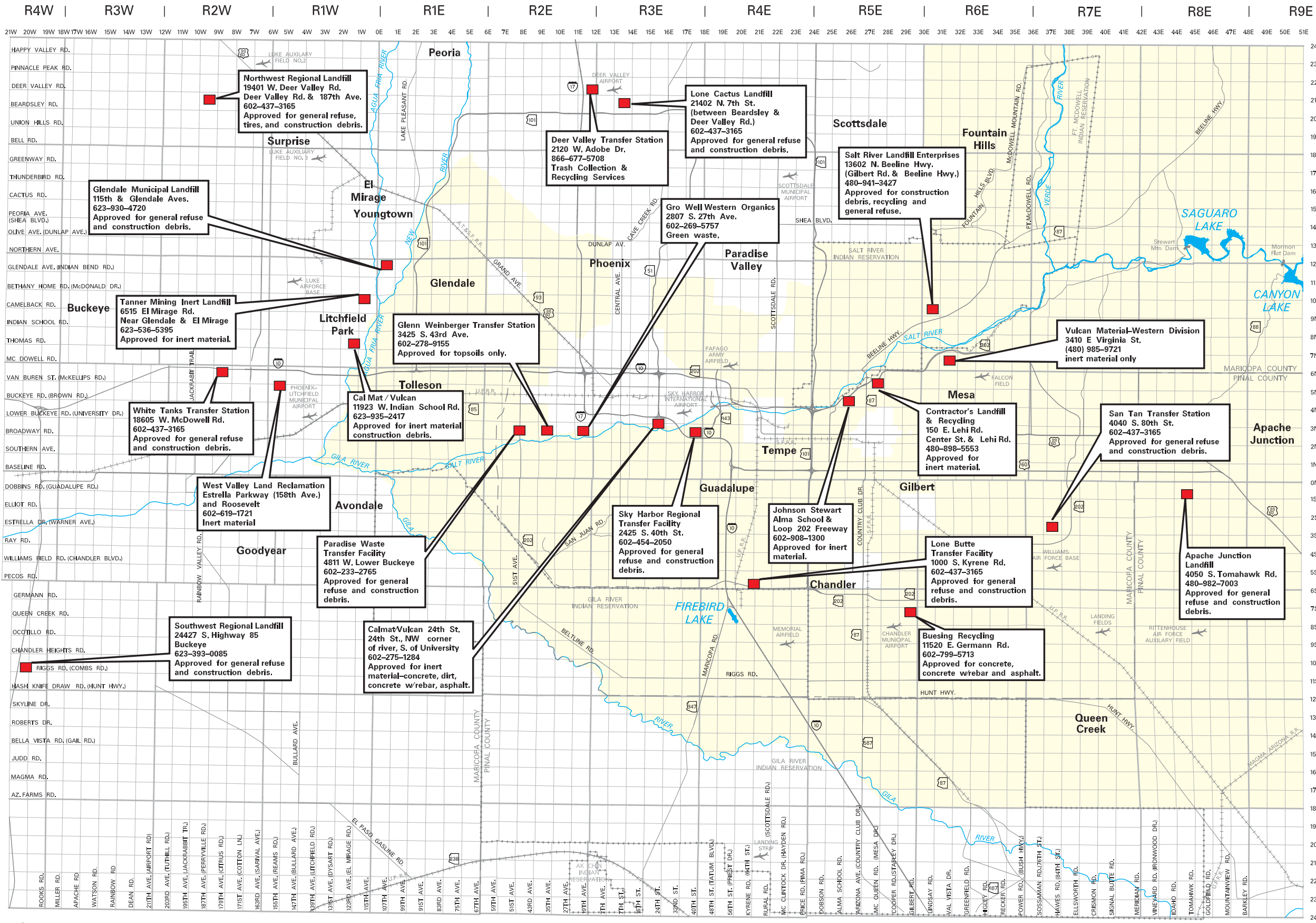

## LEGEND

- County Boundary
- Indian Reservation Boundary
- Approved Landfill Sites

- T4N CONSTRUCTION DEBRIS** includes solid waste from construction, repair, or remodeling of buildings or other structures (Does not include asbestos-containing material or treated wood poles or crossarms)
- T3N GENERAL REFUSE /HOUSEHOLD WASTE** includes solid household waste such as garbage, trash, rubbish and refuse. (Does not include construction, landscaping or demolition debris.)
- T2N GREEN WASTE** solid waste from plants (leaves, limbs, grass, trees, etc. It does not include lumber, paper and other plant-derived products).
- LANDSCAPE RUBBLE** that may contain inert material and no more than 10% vegetative material.
- T1N INERT MATERIAL** includes uncontaminated non-decomposing material such as concrete, asphalt, brick, rock, gravel, sand and soil. Can include metal but only if used as reinforcement in concrete. (Does not include glass or metal not contained in concrete.)

**\* No Liquids or Lighting Wastes to any Landfill.**

Contact Environmental Compliance Division, for disposal of any petroleum contaminated soil or asbestos containing material.  
 Wendy Crites: 6-2321  
 Jeff Edmister: 6-8077  
 Dave Sultana: 6-8118  
 MP Environmental: 602-278-6233  
 800-833-7602

Contact EHS Audit for approval of any landfills not shown on map.  
 Lou Klejbuk: 6-8109  
 James Stephan: 6-8103



SRP makes no representation as to the accuracy of this mapping product nor as to its fitness for a particular purpose.

©2013 Salt River Project (SRP)



